

2025 EDUCATION FURNITURE

Flexible Furniture for Modern Learning

VOLUME 49



VIEW MORE
CATALOGUES ONLINE
[empirefurniture.com.au/
catalogues](http://empirefurniture.com.au/catalogues)

HUGE STOCK

Classroom Desks & Chairs
Ready to Go



Scan To View
Recent Fitouts



1800 571 988
empirefurniture.com.au



Queensland Government

One of the Preferred Suppliers for QLD Government Furniture & Emergency School Furniture
Whole of Government SOA – QED 104526
Contact us for Approved Products List. www.empirefurniture.com.au/soa



New South Wales Government

Empire Office Furniture is an approved supplier for the NSW Government, under the Office and Education Furniture Contract No. 771. Empire is one of the "Tier 1" suppliers approved to fulfil orders up to and above \$150,000. Empire is approved to supply furniture from 12 product categories, across all NSW regions.

Education
furniture
buy online



it's easier with
empire
education furniture

The Empire Process



Consultation

We listen carefully to understand the vision for your spaces



Design

We work alongside your team to ensure solutions are as per your vision



Visualisation

We work with our design team who will create 2D & 3D renders to enable you to visualise your spaces



Implementation

Our team supports you in every aspect of the journey from planning, production, delivery, placement and removal of rubbish



After Sales Service

This is not the end of our journey with you - we are only a phone call away, with a dedicated account manager appointed to your school





Index

Advanced Furniture Testing	2
About Empire	3
Indigenous Designs	4 - 6
Acoustics in the Classroom	7
Empire Projects	8 - 9
Flexible Furniture for Modern Learning	10 - 17
Classroom Essentials - Plato Student Chair	18 - 19
Classroom Essentials - EDCO Cantilever Chairs	20 - 22
Stools	23
Classroom, Breakout & Training Chairs	24 - 27
Classroom Essentials - Grow Student Desks	28
Quadric Student Tables & Benches	29
Classroom Essentials - Lasso Desks	30 - 31
Acer Flexible Table Range	32 - 36
Tables	37
Island Table System	38
Creative Seating	39
Habitat Range	40 - 42
In The Round	43
Rainbow Modular Soft Seating	44 - 45
Shape Ottomans	46 - 47
Brissie Ottomans	48 - 49
Soft Seating - Sunrise	50
Soft Seating - Benchmark	51
Soft Seating - Fonzetta, Lion & Tasmania	52
Soft Seating - Flight, Wing, "Q" & Chai Lounges	53
Soft Seating - Origami	54 - 55
Soft Seating - Elements	56 - 58
Steamroller Mobile Maker Tables	59
Classroom Rugs	60
Benches & Tables	61
Teaching Aids	62 - 63
General Learning Area Dividers	64
Mobile Trolleys	65
Storewell Storage	66
Cubo Storage	67
Book Storage	68
Tote Trolleys	69
Optima Library Shelving	70
School Lockers	71 - 73
Portable Stages & Choral Risers	74 - 75
Manual Arts Benches & Sick Bay	76
Aluminium Outdoor Furniture	77
Sterling Classroom Furniture Range	78 - 79
Whiteboards & Notice Boards	80
Admin Furniture - Altura Height Adjustable	81
Admin Furniture - Shipshape Range	82 - 83
Admin Furniture - Citi System	84 - 85
Admin Furniture - Office Chairs	86 - 87
Admin Furniture - Steel Storage	88 - 89
Colour Palettes	90 - 91
LAMINEX Commercial board offer	92
POLYTEC Commercial board offer	93



ADVANCED FURNITURE TESTING

The New Benchmark in Certification

Who is Advanced Furniture Testing?

Advanced Furniture Testing is an accredited independent laboratory which tests commercial and education furniture to specific Australian and international furniture standards.

In its mechanical testing laboratory, Advanced Furniture Testing conducts tests using specialised technical apparatus which simulate real-life use and foreseeable misuse for many types of furniture.

Advanced Furniture Testing is accredited by the National Association of Testing Authorities (NATA). It is authorised to test and certify furniture to 14 international furniture standards and is regularly audited by NATA to ensure a high level of technical competence and integrity.

Certification = Reduced Risk = Peace of Mind

The most technologically advanced furniture testing laboratory in the Southern Hemisphere.

Empire has Australia's largest selection of tested & certified education furniture.



Approved by
Advanced Furniture Testing
tested to:
AS/NZS 4610.2:1999
Furniture - School and Educational
Chairs - Strength, durability and stability

Certificate No:
AFT001
26 April 2023

Supplier: **Shape Furniture**
Description: **Plato Student Chairs**
PLCH09PLCH133PLCH135PLCH409PLCH449
Seat Height: **300 mm, 335 mm, 355mm, 400 mm & 460 mm**
Tested at: **Sizemark 3/4/5/6 Severe**

Certification is based on the above standard and any additional testing/judicial assessment conducted by Advanced Furniture Testing during auditing processes.
The supplier having agreed to maintain the compliance of the product and shall submit to retesting if its specifications change.

Sizemark 3, 4, 5 & 6 was tested for strength, durability and stability at severe level. Dimensionally, the sizemark range is 3 - 6 (indicative only).

Tim Neale
Technical Manager
Date Approved - 26 April 2018

ADVANCED FURNITURE TESTING
Advanced Furniture Testing
5/4 - 6/24 Macquarie Street
Rockdale NSW 2216 - AUSTRALIA



It's Easier With Empire!

Empire Furniture has been supplying educational and school furniture in Australia for 40 years. We understand that this special application requires robust furniture which will withstand the heavy usage of students everyday.

Our Education range is independently tested and certified to specific Australian and international furniture standards. This guarantees Australia's safest and strongest furniture with an extensive warranty.

For exceptional customer service, and all your furniture needs contact Empire first!



Credentials



One of the Preferred Suppliers for QLD Government Furniture & Emergency School Furniture. Whole of Government SOA – QED 104526

Empire Office Furniture is an approved supplier for the NSW Government, under the Office and Education Furniture Contract No. 771. Empire is one of the "Tier 1" suppliers approved to fulfil orders up to and above \$150,000. Empire is approved to supply furniture from 12 product categories, across all NSW regions.



YINDI

YINDI Manufacturing was established in 2022 as a First Nations manufacturer in the office furniture sector supply chain in Australia.

YINDI means Mother in Yolngu (North-East Arnhem land) language and is a kinship term referring to the connection that the Australian Aboriginal clans have between themselves.

YINDI's vision is to build socioeconomic independence for First Nations people through employment opportunities.





JIMMY PIKE

Walmajarri Aboriginal artist, Jimmy Pike (1940-2002) was born east of Japingka, in the Kimberley region in Western Australia.

Taking flora and fauna inspiration unique to his Australian desert life, Jimmy Pike utilised whatever medium he needed to express his stories in his art, and not necessarily traditional ones. Lino printing was a favourite medium and he had a passion for the vibrancy of felt tip pens.



Robyn Caughlan

BY materialised

Robyn Caughlan is a warm, spiritual, creative soul "blessed with a multicultural heritage" – her father originating from Ireland, and Aboriginal mother from the Darug and Darkinjung lineage in NSW. Her journey into art began at the age of 30 and has "filled a void in me that I thought would never be filled."

Robyn's contemporary Aboriginal style is re-imagined through furnishing textiles and wall covering, with her first Materialised collaboration, Dream.

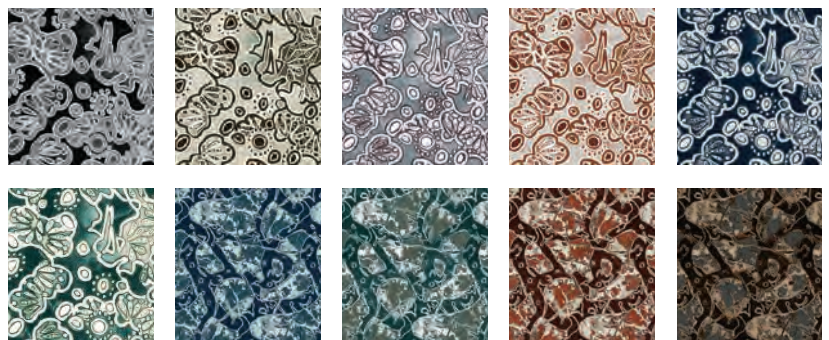



Sugarbag Dreaming 'Saltbush'
by Rosie Ngwarraye Ross



Rosie Ngwarraye Ross

Born in 1951 near Amaroo Station, Northern Territory, Rosie depicts the bush medicine plants and wild flowers from around her country near Ampilatwatja. She has a bold expressive style and often omits the sky from her compositions, combining both aerial and frontal views. Sugarbag is a name used for both the honey made by the native bees and also for the sweet nectar that comes from the big yellow flowers of the 'tarrkarr' trees.

Other Designs by:

Kathleen Korda
Annunciata Nunuk Wilson
Jean Baptiste Apuatimi
Jean Ngwarraye Long

Osmond Kantilla
Susan Marawarr
Lee-Anne Williams

WILLIE WESTON

Uniting contemporary First Nations design and acoustic functionality, the Autex Acoustics® x Willie Weston collection has been curated for education, government and commercial spaces.

Locally manufactured on Cube™ and Quietspace® Panel, the range is comprised of eight designs in 21 colourways and is entirely carbon neutral.

The specification of each design contributes to fair and equitable income for each artist via Willie Weston, a profit-for-purpose business working in partnership with First Nations artists to support the integration of contemporary First Nations design into the built environment.

Features:

- Carbon neutral
- NRC 0.45 - 0.85
- Available in 6 mm, 12 mm, 24 mm, and 25 mm thicknesses
- Available in 2400 mm, 2700 mm, and 3000 mm lengths
- Group 1 fire rating
- Safe, water-based, UV cured ink
- Locally manufactured in Australia

The Collection

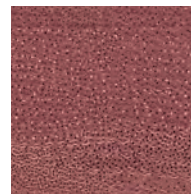

Durrmu (KK)
"Berry"

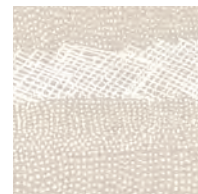

Jilamara
"Sand"



Native Seeds
"Olive"



Pandarus
"Eucalypt"



Sugarbag
Dreaming
"Ghost Gum"



Sugarbag
Dreaming
"Saltbush"



Syaw (Fish Net)
"Woolybutt"



Water Levels
"Marine"



Wak Wak
"Storm"

Noise Reducing Acoustic Solutions

NOISE-REDUCING "ACOUSTICO" PANELS

Redefine your school environment with premium acoustic solutions from Empire.

- Effectively Controls reverberated noise
- Suitable for Walls and Ceilings
- Eco-Friendly
- Group 1 Fire Rated
- Unlimited design choices
- 12mm Ceiling Tiles APCTXX
- 12mm Wall mounted pinboard/panels (semi-permanent) APSAXX
- 6mm cut to shape, custom wall decorations APSHAPEXX

PEEL & STICK ACOUSTIC WALL TILES

Custom Peel & Stick

Transform your walls into acoustic notice-boards AUPSWT0606Q6

- 35 Colours to choose from
- Eco-Friendly
- Velco-Compatible and Pinnable
- These tiles are "Permanent Stick" (Non-Permanent also available APSAXX)
- Pack of 6 Tiles (covers 2.16 sq.m)
- Each Tile is 600mm x 600mm (12mm)
- Custom designs also available



We also offer a range of Acoustic Ceiling Hung solutions. Please enquire.

Empire Projects Division

Empire has an experienced and dedicated Major Projects team which ensures the smooth flow of all fit-out processes.

Our Project Managers plan, organise and oversee the fit-out from sign-off through to completion.

Empire's Interior Designers will create functional spaces to meet your requirements. Our in-house studio produces a large range of resources from preliminary 2D and 3D renders of your fit-out to manufacture and installation drawings.

Well versed in working with architects, builders and contractors, we use only accredited installation teams.

With a wealth of education experience, we can project manage the entire process for you. It's time to take the stress out of school fit-outs.

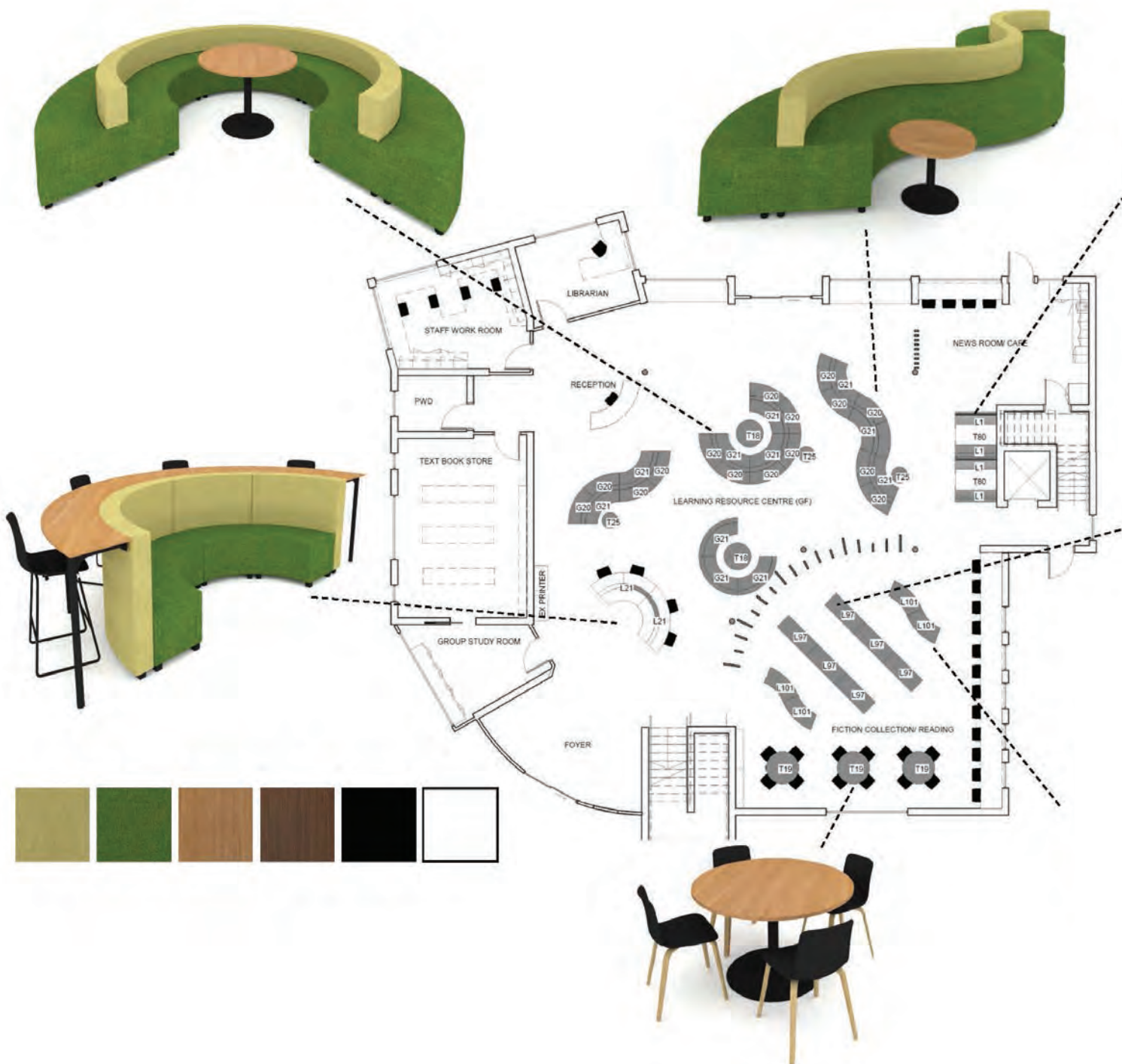



View realistic 2D and 3D renders of your space before placement of order.



Flexible Furniture For Modern Learning

The modes for future learning highlight different ways in which learning occurs. These spaces need to be flexible and adaptable, and easy to rearrange so the learners can move from an entire group setting, to smaller collaborative groups and individual settings easily.

Understanding Key Learning Styles

Independent



Learn on my Own

Independent Learning

Private learning spaces where students can think, reflect and apply their learning.

Students develop creativity and intellectual curiosity.

Based on the 'Cave' Archetype. The furniture in these spaces places emphasis on acoustic and visual privacy to help students focus on independent work.

Collaborative

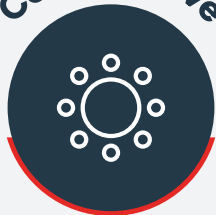

Learn with Others

Collaborative Learning

Enhanced learning through group work to encourage communication and collaboration.

Students are able to share ideas and develop problem solving and reasoning skills.

Based on the 'Watering Hole' Archetype. The furniture in these spaces is mobile and easily reconfigurable to easily allow movement to different configurations.

Guided



Learn from an Expert

Guided Learning

Focused learning from a presenter whether that is a teacher or peer.

Students develop listening and communication skills.

Based on the 'Campfire' Archetype. These areas are generally furnished with soft seating but a 'campfire' configuration can also be achieved using desks and tables.

Creative

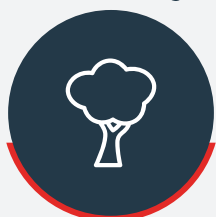

Make, Explore
and Investigate

Creative Learning

Allows students to build knowledge and develop skills using creative techniques.

Allows students to develop their own unique learning styles as well as outside the box thinking.

Layout 1 - Flexible Learning

30 Students

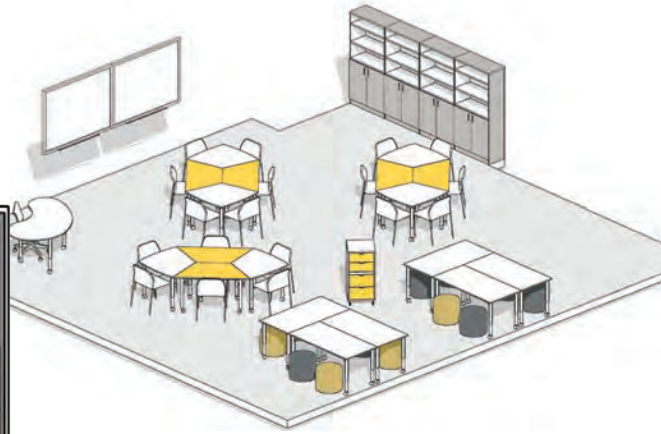
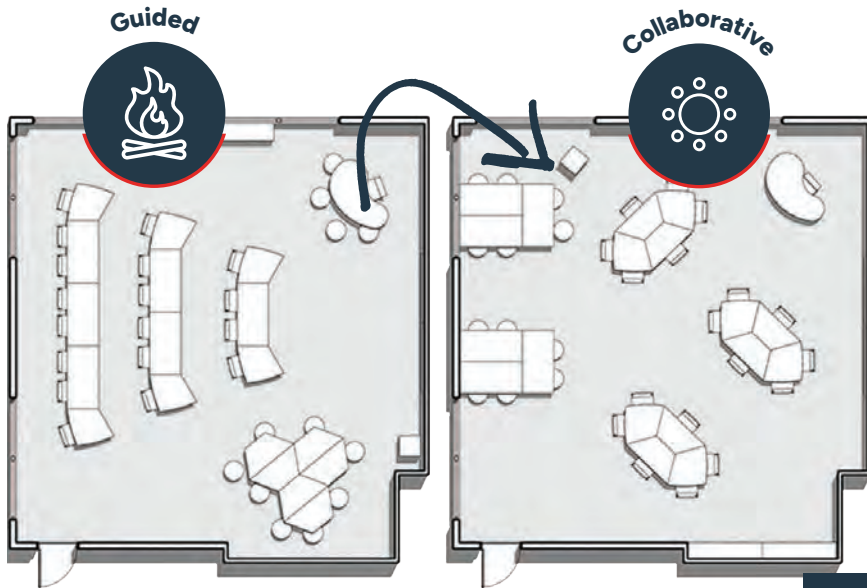

Easily Reconfigurable!

Products

- 1 x Satellite Teachers Caddy
- 1 x Acer Bean Table - **(Custom Shape)**
- 1 x Teachers Task Chair
- 6 x 1500 x 750mm tables - Echo Flip
- 6 x Acer Trinity Table
- 6 x Acer Trapezium Table - **(Custom Shape)**
- 12 x Round Ottomans
- 18 x Student Chairs



Gumdale State School - Collaborative Learning Space

Example Layouts - Learning Spaces

Layout 2 - Flexible Learning

28 Students

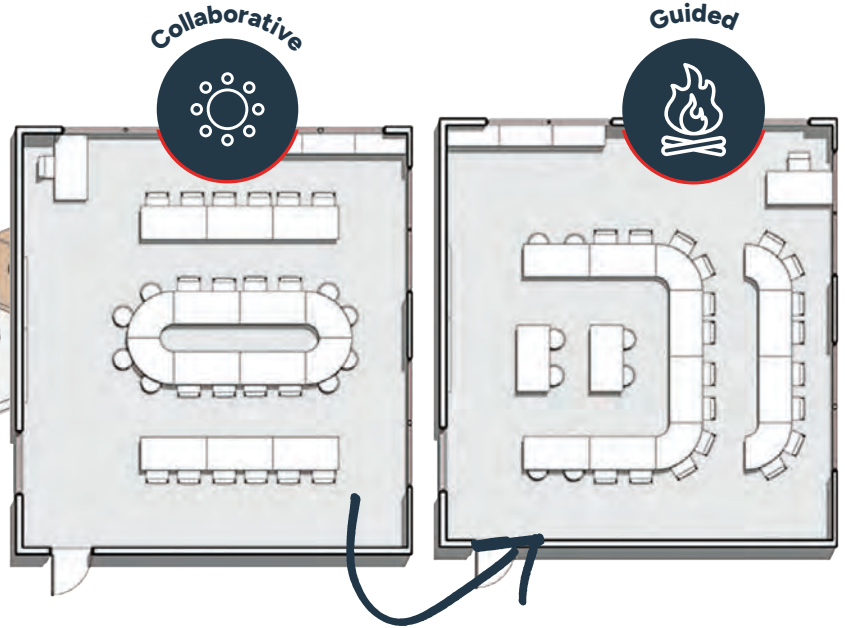
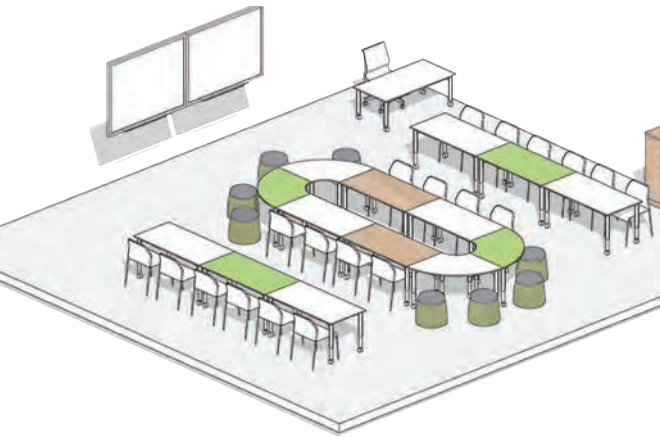

Products

- 1 x Teachers Desk
- 1 x Teachers Chair
- 8 x Round Ottomans
- 4 x Acer Quarter Tables
- 8 x Acer 1500 x 750mm Tables
- 20 x Student Chairs
- 3 x Storage Cupboards



Effective learning spaces are mobile & flexible. They provide students with a choice of where and how they learn.

3D Render - Guided Learning Space

Layout 3 - Collaborative Learning Space

30 Students

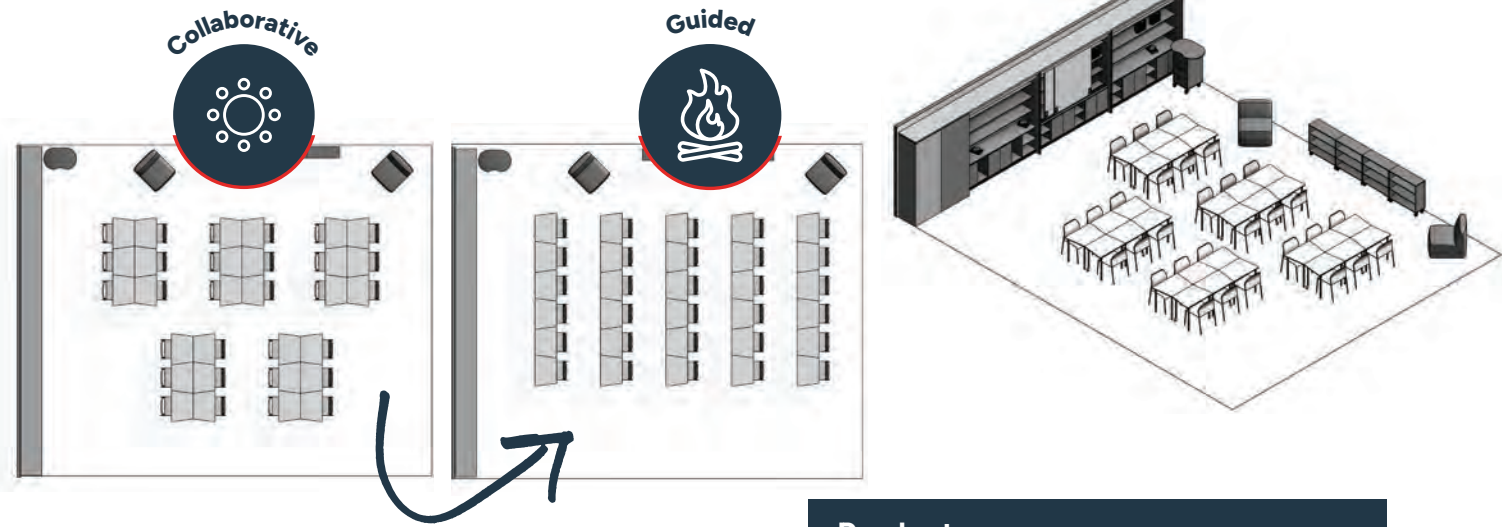

3D Render - Collaborative Learning Space

Example Layouts - Learning Spaces

Layout 4 - Collaborative Learning

30 Students

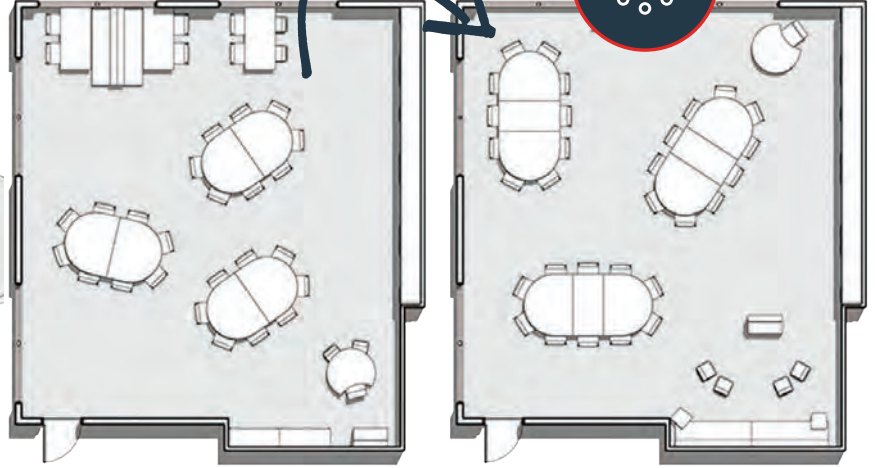
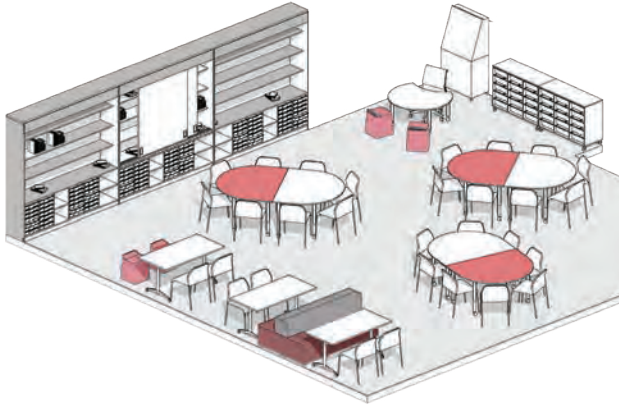

Products

- 1 x Fusion Learning Centre
- 1 x Acer Crescent table
- 1 x Teachers Chair
- 4 x Peekaboo Stools
- 6 x Acer D-End tables
- 3 x Acer 1500 x 750mm Tables
- 30 x Student Chairs
- 2 x Straight Rainbow Lounges
- 2 x Laptop Tables
- 2 x Storage Cupboards



Ipswich State High School - Breakout Space



Bundamba State School - Collaborative learning



Bundamba State School - Collaborative learning

Layout 5 - STEM Spaces

24 Students

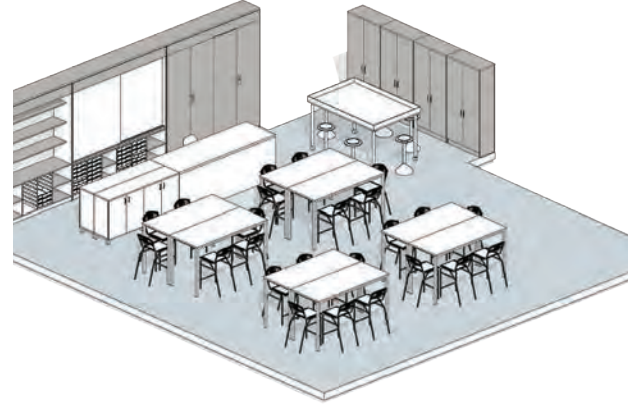
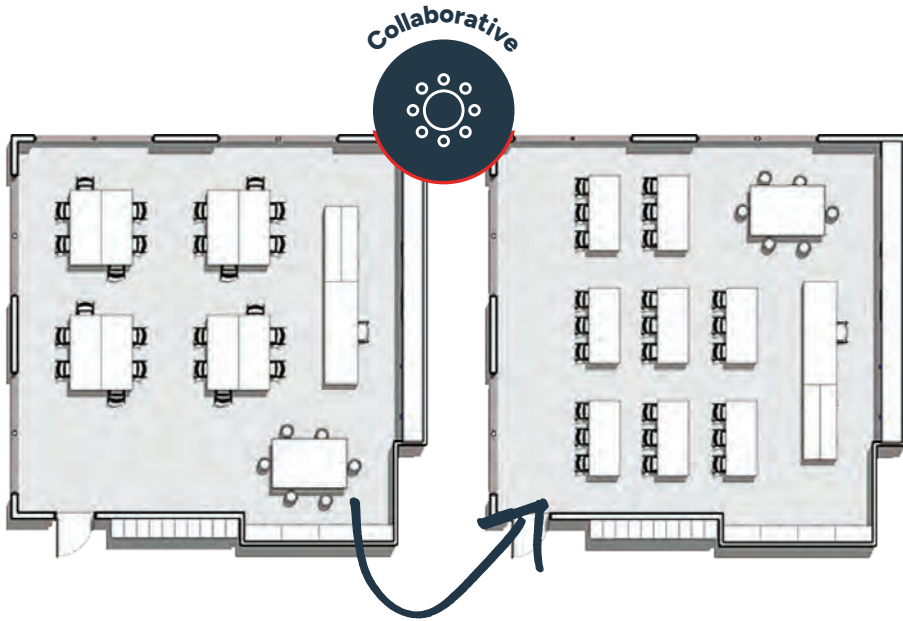

These 'lab style' learning spaces are designed for project based learning. They **encourage critical thinking** and **collaboration between students** and **inspire a generation of future innovators.**



Ipswich State High School - STEM Space



Oakhill College – STEM Space



Wyreema State Primary School - STEM Space

Recent Fitouts - Staff Spaces



Thornlands State School - Staff Breakout



Taigum State School - Staff Breakroom



Parramatta State School - Staff Breakout



Wyreema State School - Staff Lunch Room



Thornlands State School - Staff Meeting

Recent Fitouts - Library & Breakout



Newman Catholic College - Library



Mackillop Catholic College - Library



Narangba Valley State School - Senior Learning Hub



Genesis Christian College - Senior Study Space



Woree State High School - Flexible Learning Space

Plato Student Chair



10 YEAR WARRANTY

125 kg

MAX USER



Tested to AS/NZS 4610.2 Education Chairs
180kg Static Load Test
200,000 Seat/Back Fatigue Test

Summary:

Plato is a versatile one piece injection moulded chair which promotes good posture to help reduce fidgeting and to aid in the learner's attention span. Plato is lightweight, durable and is made to withstand school environments.

Features:

Also available in smaller heights 240/260/280/300mm (minimum quantities may apply)
Core colour range: Slate, Pacific Blue, Leaf Green
Extended colour range available (minimum quantities may apply)

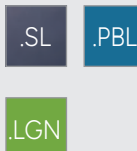

Grade	Seat Height (MM)	Code	Suits Desk Height. (MM)
Prep-1	335	PLCH335	550-600
Prep-3	355	PLCH355	600-650
4-6	400	PLCH400	625-725
6-12	460	PLCH460/L	725-750
6-12	460	PLCH460LU (WITH SEAT PAD)	725-750

Plato Chair with Link



• Optional Seatpad



Left side when seated



Right side when seated

- New release (PLCH460L): The ever popular Plato chair (460mm) is now also available with easy linking feature ideal for school halls, assembly areas, canteens etc.
- This model also has the option of an upholstered seat pad (PLCH460LU)
- Also available chair trolley for easy move and reset (TROLLEY01)



Optimal Height Guide*

Children's stature varies greatly within each classroom. For this reason Empire offer 9 x GROW desk heights and 5 x PLATO chair heights. This enables you the best opportunity to select the ideal furniture for your students.

<p>Grade Kindy Chair Height 300mm Desk Height 550mm</p>	<p>Grade Prep - 1 Chair Height 335mm Desk Height 600mm</p>	<p>Grade Prep - 3 Chair Height 355mm Desk Height 650mm</p>	<p>Grade 4 - 6 Chair Height 400mm Desk Height 700mm</p>	<p>Grade 6 - 12 Chair Height 460mm Desk Height 750mm</p>

*Important - this is a guide only, based on the Australian Standard. Empire cannot be accountable for incorrect product selections.

EDCO Cantilever Chair

Modern ergonomically designed cantilever chairs absorb the bounce of active children, so teachers don't have to. The robust seat surface is easy to clean and resists scratches. The C-frame makes raising the chairs on desks and tables quick and safe. Glides provide stability and protect floors from abrasion.



A convenient grip hole in the seatback makes carrying this lightweight chair effortless.



Supporting ribs



Ergonomic Design

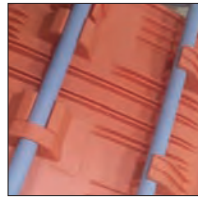

Strong & easy fixing system



Glides provide stability and protect floors from abrasion



Sturdy light metal frame

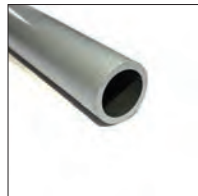

Strong steel cantilever frame



Nesting Chairs



A

B

C

D

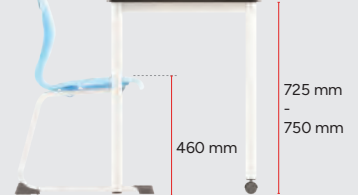
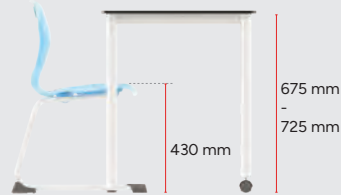
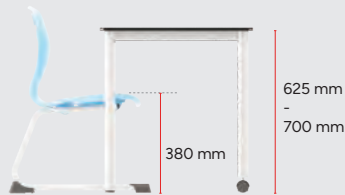

EDCO Cantilever Chair		A	B	C	D
	Seat Height	350 mm	380 mm	430 mm	460 mm
	Grade	Prep - 3	3 - 5	4 - 6	6 - 12
	Code	EDCHC350	EDCHC380**	EDCHC430*	EDCHC460*
	Seat Width & Depth	360 x 380 mm	360 x 380 mm	430 x 450 mm	430 x 450 mm
	Overall Height	620 mm	680 mm	790 mm	820 mm
	Recommended Table Height	550-650 mm	625-700 mm	675-725 mm	725-750 mm

*Stocked range: Any colour shell on Black Frame. **Stocked range: Charcoal or Yale Blue shell on Black Frame. Other versions – lead times apply

Comfortable Seating with Flex

Born from the collaborative efforts of architects, interior designers, educators, product designers and furniture manufacturers, Edco chairs are the result of years of research into the movements, habits, uses and misuses of students.

These insights have led to the careful selection of materials, ergonomic design and durable construction that make Edco chairs an ideal student seating solution.

Edco chairs maximise sustainability and minimise maintenance costs with replaceable glides, shells and frames.



Sturdy light metal frame

Shell Colours

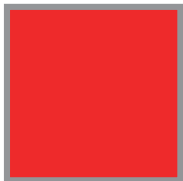

Crimson



Tangerine



Bumblebee

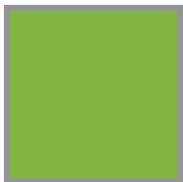

Pear

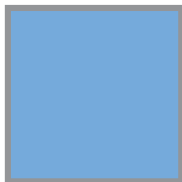

Sky blue



Yale Blue

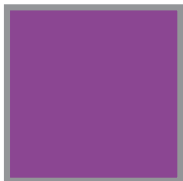

Violet



Charcoal

Metal Frame Colours



White



Grey



Black



Charcoal



Colour codes refer to different seat heights according to DIN EN 1729.



Glides provide stability and protect floors from abrasion



Plastic

Felt

Replaceable glide elements

Strong & easy fixing system

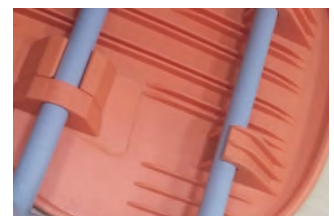

EDCO 4 Leg Stool

The Edco stool is a versatile solution for school science labs, libraries and anywhere that requires bench seating; available in three heights.

- Ergonomic and flexible back with a leaning seatback can help promote correct posture with high benchtops.
- Robust seat surface resists scratches and is easy to clean.
- Glides provide stability and protect floors from abrasion.
- Comfortable footrest.



Supporting ribs



Ergonomic Design



Strong & easy fixing system



Glides provide stability and protect floors from abrasion



Footrest



Strong steel frame



Nesting Chairs

Shell Colours

- Crimson
- Tangerine
- Bumblebee
- Pear
- Sky blue
- Yale Blue
- Violet
- Charcoal

Metal Frame Colours



White

Grey

Black

Charcoal



BIFMA

EDCO 4 Leg Stool		A	B	C
	Seat Height	560 mm	610 mm	660 mm
	Grade	6 - 12	6 - 12	6 - 12
	Code	EDSTL560	EDSTL610	EDSTL660*
	Seat Width & Depth	360 x 380 mm	430 x 450 mm	430 x 450 mm
	Overall Height	860 mm	970 mm	1020 mm
	Recommended Table Height	820 mm	850 mm	900 mm

*Stocked range: Any colour shell on Black Frame. Other versions – lead times apply.

Stools

PEEKABOO STOOL

PEEK01

- 
Dusk
- 
Duck Egg
- 
Gravel
- 
Misty Grey
- 
Stone Green
- 
Raspberry Red



The Peekaboo is perfect for a wide variety of uses. It features a seamless design to add strength and stability, while being lightweight, which means it is easily stacked and easy to move.

- Size: 400W x 410D x 467Hmm
- IF Design Award winner 2020
- Solid and lightweight design
- 12 stackable
- Open backrest for easy handling
- Suitable for both indoor and outdoor use*



PLATO STOOL

PLSTXX

The Plato stool encourages movement and also improves the attention span of the learner. Made from polypropylene that is easy to wipe down and clean.

- Heights: 370mm or 450mm
- Diameter 330mm
- Base encourages movement



BUTTON ACTIVE SITTING STOOL

BTTN400W/500W

- Seat height: 400 and 500mm
- Diameter 300mm
- Convex base design promotes healthy sitting with mobility
- Available in Blue, Green, Orange, and Red



PERCH STOOL

PERCH01



- Gas lift
- Seat height range 595–840mm
- Seat diameter 300mm
- Available in Black or Blue



TRINA STOOL

TRINA01.XX



- Active Seating wobble stool
- Underseat hand grip
- Solid PP material

- 300mm dia x 400mm H
- 3 Colours – Fuchsia, Mint and Sky Blue

BARBELL STOOL

BARBELL01



- Gas height adjustable 400–500mm Range
- Slip resistant TPE base
- Fabric covered seat



A1

PU LAB STOOL

Features:

- High quality moulded PU
- Hard wearing and easy to clean

	Style	Code
A1	Lab Saddle	LABST02
A2	Lab Saddle (with Drafting kit)	LABST02D
B1	Lab Chair	LABCH23N
B2	Lab Chair (with Drafting kit)	LABCH33N



- Height range: 340–580mm

B2

SIDEKICK SWIVEL STOOL



- Height range: 560–820mm

3 YEAR WARRANTY



- Seat height: 530mm to 740mm
- Seat diameter 400mm
- Black leather-look (PU) seat
- Chrome finish on base and gas spring

Without drafting ring
SIDE01
With drafting ring
SIDE02

3 YEAR WARRANTY

Student & Breakout Chairs

Cato



CATO RANGE (6 colours)

Seat heights: 310, 350, 385, 445mm
CATO445. Stacks 10 high, charcoal only
Stool seat height: 650mm CATO650.
Splayed legs minimise potential for tipping, stacks 7 high, also available with ply Oak timber veneer seat
Stool with back seat height: 650mm
CATO650B. Art, Graphics and Science stool, stacks 7 high
Gas lift seat height range: 380–520mm
CATOGAS.
Super strong, full steel sub-frame



Examiner Stacking Stool



Colours



Unitab



EXAMINER STACKING STOOL

Seat height - 600mm/650mm/700mm
Powder coated black heavy duty steel frame
Stackable
Polypropylene seat available in 9 colours
Black, Anthracite, Blue, Charcoal, Fuchsia, Green, Purple, Teal, Wedgwood

7 YEAR WARRANTY

UNITAB ARMCHAIR UNITAB01

The Unitab chair offers a left and right hand tablet and storage all in one. Ideal for training rooms, universities and general classrooms.
Available in Green (other colours available)
Left and right-hand tablet
Storage underneath
Cup holder and pen well

7 YEAR WARRANTY

Mixx 'N' Match & Play Chair

MIXX 'N' MATCH

THE MIXX RANGE
Australia's most versatile range of high quality breakout visitor seating.

BASE STYLE	CODE	DETAIL (ALL PRICES PLASTIC SHELL)
A 4 LEG	MIX61xx	Metal frames options
B SLED	MIX71xx	Chrome/Black/Woodgrain
C 4 LEG TIMBER	MIX61Tx	
D STOOL (630 or 760H)	MIX630x/760x	Black or Chrome frame
E TIMBER LEG STOOL	MIX630Tx/760Tx	Black or Chrome foot ring
F 5 STAR BASE	MIX13x	Black nylon, gas lift and castors
G UPHOLSTERED SEAT	Optional Upgrade	Warwick gravity fabric
H FULLY UPHOLSTERED	Optional Upgrade	Warwick gravity fabric
I ARMS	Optional Upgrade	Lt.Grey/Black/White

VARIETY OF LEGS AND ARMS OPTIONS

* Plastic shell only

MANY Colours available POA



SEE THE FULL RANGE IN OUR MIXX CATALOGUE AT: empirefurniture.com.au

PLAY CHAIR



White with Bright Orange upholstered seat



PLAY61S

PLAY CHAIR	4 Leg*	Sled Base*	Barstool - 4-Leg, Chrome Only
Poly Seat/Back [#]	PLAY61P	PLAY71P	PLAY81P
Fabric Seat Only [#]	PLAY61S	PLAY71S	PLAY81S
Fabric Seat/Back [#]	PLAY61F	PLAY71F	PLAY81F

* Listed prices are for standard Poly Shell Colours on Powder Coated Frame.

FRAME: Standard Colours - Black/White/Silver Powdercoat
Optional - Chrome Frame

^ POLY SHELL: Standard Colours - White or Charcoal
Optional Deluxe Colours - Red, Aqua, Indigo, Daffodil & Pistachio



FABRIC: Lime Green, Tomato Red, Bright Orange, Sky Blue, Plum, Slate Grey & Black.

Note: Upholstery is only available on White or Charcoal poly shells

The sophisticated style of the Play chair is the ultimate point of difference to others of its kind. Training, conference, classroom, healthcare, retail & cafeteria seating.

- Versatile stacking - up to 9 chairs high
- Fan-shaped
- Polypropylene seat and back
- Frame - powdercoated steel or chrome
- Frame - 4 legs or sled base
- Great lumbar support
- Poly shells can be plain or upholstered

10 YEAR WARRANTY



PLAY71F
Fully Upholstered On Chrome Frame.

SPECTRUM (TESTED & CERTIFIED)

- FEATURES
- 10 Vibrant colours to choose from
 - Static seat load tested to 250kg
 - Suitable for indoor or outdoor use
 - Stackable SPEC61



Training Room Chairs

Verve



Linking
Capability

VERVE STACKING TROLLEY

10 x Fabric or 20 x Plastic
VERS66



VERVE VISITOR RANGE

Seat Plastic VERS61P, stackable/linkable, available with arms, writing tablet optional, Black or Navy Blue

Seat Fabric VERS61F, Black or Red

Bar Stool seat height: 762mm VERS81P. Chrome frame, Plastic seat and back, Black or Navy Blue

Seat Plastic / Fabric with MDF tablet

Tablet Left VERS63xL, Tablet Right VERS63xR (use "P" for Plastic, use "F" for Fabric)

10 YEAR
WARRANTY



Training Room Chairs

Solidworx



SWRX61W.BK

- Foldable arm rest
SWRX62W.BK



- Foldable arm rest and tablet
- Tablet on RHS
- Size W330 x D260mm
SWRX63W.BK



Stacking Trolley
SWRX66.BK



SOLIDWORX - Australia's toughest training chair

- Plastic back
- Stackable
- Foldable seat for nesting
- Iron tube leg and PU castors
- Simple and effective linking
- All components meet min of BIFMA standard
- Greenguard certified

5 YEAR WARRANTY



Grow Student Desk - 9 desks in one!

The versatile Grow Desk is height adjustable
Suits all ages from Prep to Grade 12
9 positions: 550mm to 750mm

Grow
600 x 450mm



• Curved cross-rail provides more leg room on 450mm deep model



600 x 450 includes moulded pen trayV



Grow desks feature an 18mm environmentally friendly E-Zero top with tamper-proof, moulded PP edging and a strong steel frame.

Grow leg "height indicator" ensures simple height adjustment



All New Design

Grow
600 x 600mm



• Dark Grey totes for easy maintenance

Grow
1200 x 600mm



All Grow desks pass the infamous basketball test

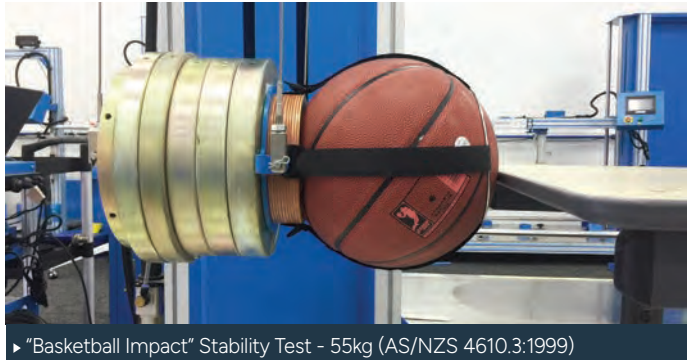

► "Basketball Impact" Stability Test - 55kg (AS/NZS 4610.3:1999)

- All new design
- Tested and Certified to the Australian Standard
- Height adjustable - 9 positions
- Height range 550 - 750mm
- 18mm environmentally friendly E-Zero top with tamper-proof, moulded PP edging
- Strong steel frame
- Stardust top

GROW DESK WITH TOTE			GROW DESK NO TOTE			GROW TOTE ONLY		
TOP	SIZE mm	CODE	TOP	SIZE mm	CODE			
Single	600W x 450D	GRDKC0604T	Single	600W x 450D	GRDKC0604	Single	500W x 400D x 90H	GRTOTER01
Single	600W x 600D	GRDKC0606T	Single	600W x 600D	GRDKC0606			
Double	1200W x 600D	GRDKC1206T	Double	1200W x 600D	GRDKC1206	Double	Pack of 2 (includes centre rail)	GRTOTER02

• Includes rails • Tapered front • Grey only

Grow tops available in speckled Stardust for easy maintenance



7 YEAR WARRANTY



Quadric Student Tables and Benches

QUADRIC TABLES FIXED HEIGHT

• 25mm steel frame

New Fully Welded Design



QUADRIC TABLES HEIGHT ADJUSTABLE

• 30mm steel frame



- H565-765
- 5 convenient height adjustments in one easy to adjust leg

	SIZE	TABLES 720mm FIXED HEIGHT	HEIGHT ADJUSTABLE 565-765mm H
A	600W x 600D	QDTB0606W	QDTB0606WT
B	700W x 550D	QDTB0705W	QDTB0705WT
C	1200W x 600D	QDTB1206W	QDTB1206WT
BENCHES - 900mm FIXED HEIGHT			
D	1200W x 600D	QDBE1206	

Core Colour:



Stardust

Extended Colours (see pg. 90)

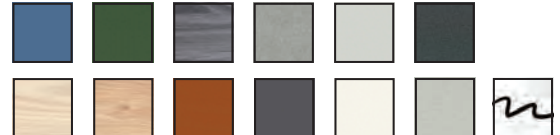

MANY Colours available POA



7 YEAR WARRANTY

Other sizes available on indent

ACER STUDY CARREL

ACTCARREL



- W900 x D600
- 720mm High (desk height)
- 1220mm overall height
- Private study carrel
- Ideal for libraries



- W900 x D600
- 720mm High (desk height)
- 1220mm overall height
- Private study carrel
- Ideal for libraries

PONDER CARREL

PDPONDER



*4 x Ponder Carrel Seating not included

- The modular design of the Ponder Carrel makes them ideal for joining together.
- W835 x D600 x H1200

MANY Colours available POA

See pg. 90

LASSO Desks



LASSO TAPER

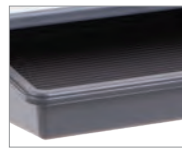

Optional Tote (T)

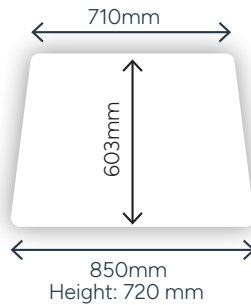

RADIUS CORNERS FOR ADDED SAFETY

LASSO TABLES - SHIELD AND TAPER TOPS

STYLE	LEGS	STATIC	MOBILE
Shield	3	LASSHIELD	LASSHIELDW
Taper	4	LASTAPER	LASTAPERW

LASSO SHIELD

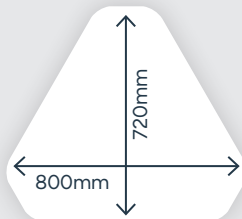

7 YEAR WARRANTY

Extended colours (see pg. 90)



OPTIONAL CASTORS FOR EASY MANOEUVRABILITY

Flexible Layouts



Table top colours:



Frame colours:

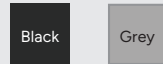

Lasso Taper Layout Options

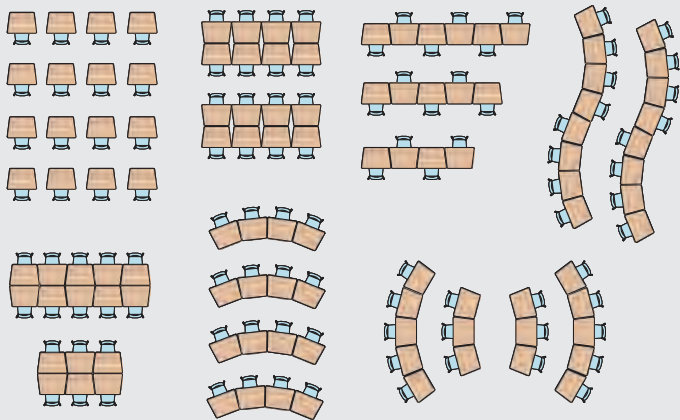

Lasso Shield Layout Options

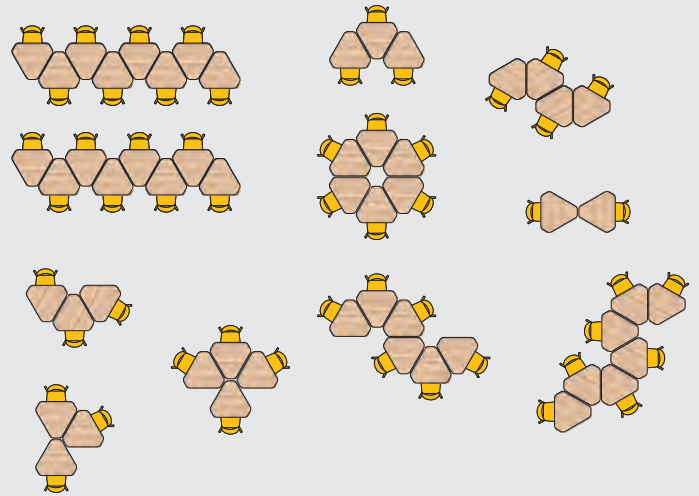

Acer Table Range

Many table settings are not adaptable to changing demands and educators are forced to work around their furniture's limitations.

It was this design flaw which inspired the innovation of our Acer Table Range. Facilitating vast permutations of table configurations in both individual and group-use contexts, our Acer Tables are perfect to liven up and improve the functionality of your space. The range includes fixed, mobile, height-adjustable and flipping frame systems, and modular top shapes that can evolve to include multiple users on demand.

The strength and flexible nature of our frame systems have enabled us to produce highly unique tables, to the extent that if you have a custom table shape in mind, we are confident our frame systems can bring your idea to life!

Check out the quality of our Acer Tables!

They're flexible and strong, perfect for sustained use in any interior environment!

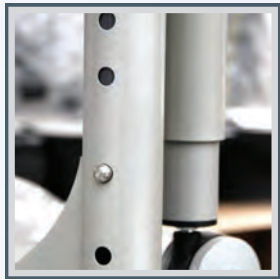

Push-Pin Height Adjustable

With high-strength 1.6mm gauge steel and a high tensile push-pin system, our legs allow 5 different table height options, without sacrificing product stability or integrity. The Acer leg has a 60mm diameter (far superior to similar products at 40mm) ensuring no movement or rattle.



Mobile Lockable Wheels

Standard with mobile, height adjustable and flipping frames, our mobile castors make reconfiguration a breeze - once you've found the perfect spot, simply lock the castors and you're set!



Optional Glides

Glides can be interchanged with castors. All height adjustable tables are available with four glides or as a combination of two glides and two castors.

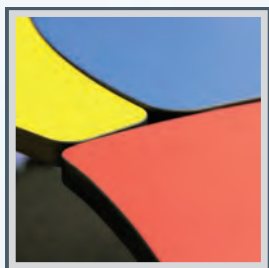

Top Quality Laminates and ABS Edging

Our table tops come standard with quality laminate finishes and high-impact ABS edging, to ensure that your top withstands your day-to-day activities, with little sign of wear.

**ACER LEG
AVAILABLE
IN SILVER
OR BLACK
RIPPLE**

Core Colours

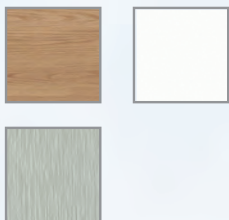

Extended Colours (see pg. 90)

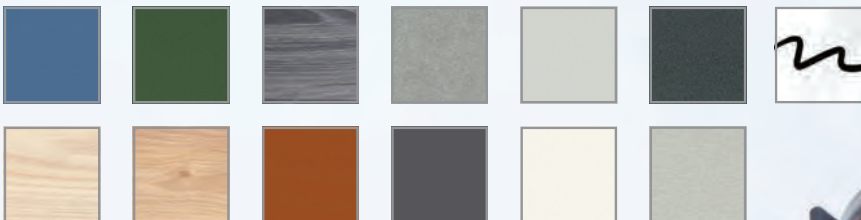

Tested to AS/NZS 4610.3
Education Tables

**No Rattle,
Guaranteed**



**7 YEAR
WARRANTY**



**MANY
Colours
available
POA**



Acer Table Range

Available Table Frames: (Check specific products to see which frames apply)

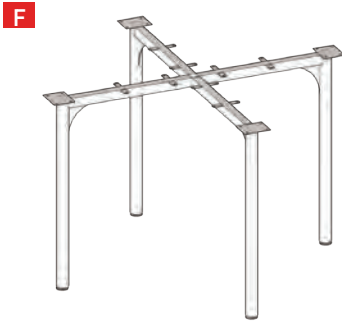

Fixed Height Leg
(with levelling feet) 720 mm high

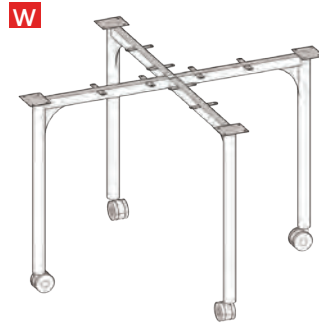

Fixed Height Leg
(with lockable castors) 720 mm high

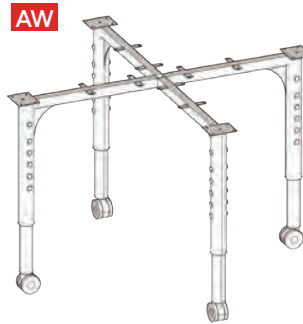

Height Adjustable Leg
(with lockable castors)
6 heights: 550 | 610 | 640 | 680 | 720 | 750 mm

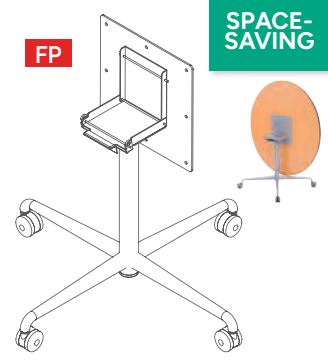

Flip Table for Easy Storage
(with lockable castors) 720 mm high

SPACE-
SAVING

Available Bench Frames: (Check specific products to see which frames apply)

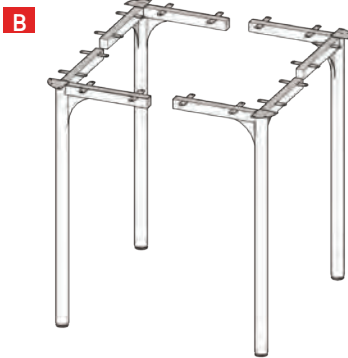

Fixed Height Leg
(with levelling feet) 900 mm high

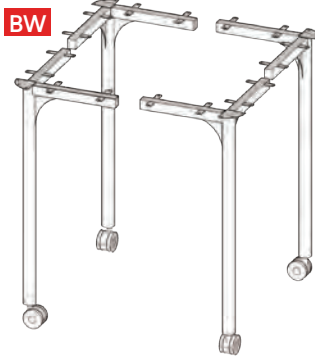

Fixed Height Leg
(with lockable castors) 970 mm high

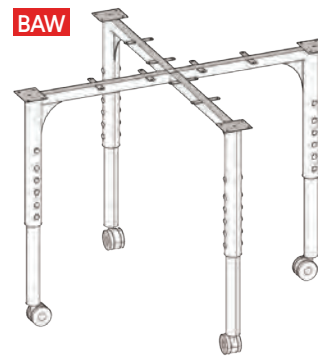

Fixed Height Adjustable Leg
(with lockable castors)
6 heights: 720 | 780 | 810 | 850 | 900 | 930 mm



Optional Bell Glides (ACBELLGLIDE)
Height adjustable tables are also available with 4 glides or in combination of 2 glides and 2 castors

COMPARE OUR TOP SIZES

Acer tables offer lower "cost per student"...
Acer 1200 mm diameter tables accommodate four students, other 900 mm diameter tables accommodate one student.

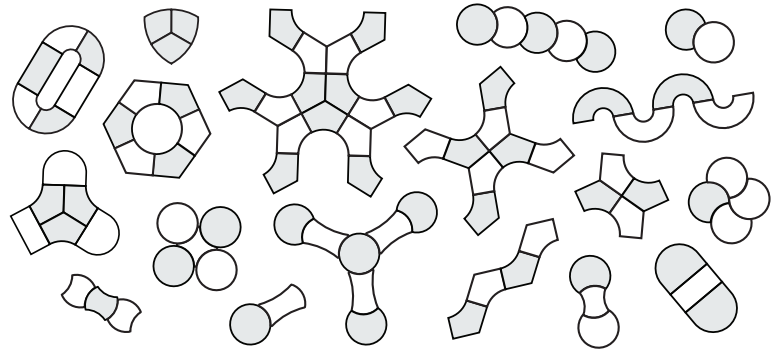

ACER

IDEAL FOR EDUCATIONAL USE

Core Top Colours:

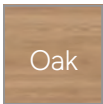

Oak

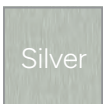

Silver



Erasable Surface



All Acer tops are 18mm thick MDF

Optional Bell Glides (AC-BELLGLIDE)

	FIXED HEIGHT WITH LEVELLING FEET	FIXED HEIGHT WITH CASTORS	HEIGHT ADJUSTABLE WITH CASTORS	BENCH HEIGHT WITH LEVELLING FEET	BENCH HEIGHT WITH CASTORS	NEW ADJUSTABLE BENCH HEIGHT WITH CASTORS	FLIP FRAME
TOP SHAPE	CODE	CODE	CODE	CODE	CODE	CODE	CODE
1a Round	ACTROUND	ACTROUNDW	ACTROUNDW	ACTROUNDB	ACTROUNDBW	ACTROUNDBAW	ACFPROUND
1b Round Whiteboard	ACTROUND.WB	ACTROUNDW.WB	ACTROUNDW.WB	ACTROUNDB.WB	ACTROUNDBW.WB	ACTROUNDBAW.WB	ACFPROUND.WB
2a Pentagon 60°	ACTPENTA60	ACTPENTA60W	ACTPENTA60W	ACTPENTA60B	ACTPENTA60BW	ACTPENTA60BAW	ACFPENTA60
3 Fan	ACTFAN	ACTFANW	ACTFANW	ACTFANB	ACTFANBW	ACTFANBAW	ACFPFAN
4 Bone	ACTBONE	ACTBONEW	ACTBONEW	ACTBONEB	ACTBONEBW	ACTBONEBAW	ACFPBONE
5 Trinity	ACTTRI	ACTTRIW	ACTTRIW	ACTTRIB	ACTTRIBW	ACTTRIBAW	ACFPTRI
6 Star	ACTSTAR	ACTSTARW	ACTSTARW			ACTSTARBAW	ACFPSTAR
7a Crescent	ACTCRESC	ACTCRESCW	ACTCRESCW	ACTCRESCB	ACTCRESCBW	ACTCRESCBAW	ACFPCRESC
7b Crescent WB	ACTCRESC.WB	ACTCRESCW.WB	ACTCRESCW.WB	ACTCRESCB.WB	ACTCRESCBW.WB	ACTCRESCBAW.WB	ACFPCRESC.WB
8a Arc	ACTARC	ACTARCW	ACTARCW	ACTARCB	ACTARCBW	ACTARCBAW	
8b Arc Whiteboard	ACTARC.WB	ACTARCW.WB	ACTARCW.WB	ACTARCB.WB	ACTARCBW.WB	ACTARCBAW.WB	
9a D-End	ACTDEND	ACTDENDW	ACTDENDW	ACTDENDB	ACTDENDBW	ACTDENDBAW	
9b D-End Whiteboard	ACTDEND.WB	ACTDENDW.WB	ACTDENDW.WB	ACTDENDB.WB	ACTDENDBW.WB	ACTDENDBAW.WB	
10 Quarter	ACTQUART	ACTQUARTW	ACTQUARTW	ACTQUARTB	ACTQUARTBW	ACTQUARTBAW	
11a Rectangle	ACT1575	ACT1575W	ACT1575W	ACT1575B	ACT1575BW	ACT1575BAW	
11b Rectangle Whiteboard	ACT1575.WB	ACT1575W.WB	ACT1575W.WB	ACT1575B.WB	ACT1575BW.WB	ACT1575BAW.WB	
12 Helix	ACTHELIX	ACTHELIXW	ACTHELIXW	ACTHELIXB	ACTHELIXBW	ACTHELIXBAW	ACFPHELIX
13 Axis	ACTAXIS	ACTAXISW	ACTAXISW	ACTAXISB	ACTAXISBW	ACTAXISBAW	ACFPAXIS

Acer Table Range

1

ROUND



Fixed Height
ACTROUND

Height Adjustable (Mobile)
ACTROUND AW



7

CRESCENT



Fixed Height
ACTRESC

Height Adjustable (Mobile)
ACTRESC AW



9

D-END

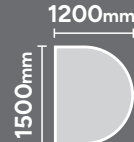

Fixed Height
ACTDEND

Height Adjustable (Mobile)
ACTDEND AW



11

RECTANGLE

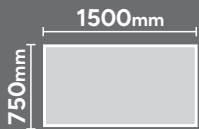

Fixed Height
ACT1575

Height Adjustable (Mobile)
ACT1575 AW



"NO RATTLE, GUARANTEED!"



Tested to AS/NZS 4610.3

2

PENTAGON

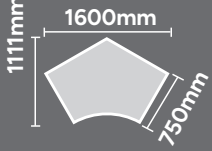

	i (mm)	ii (mm)
A 60°	1600	1111



7 YEAR WARRANTY



Tested to AS/NZS 4610.3 Education Tables

A

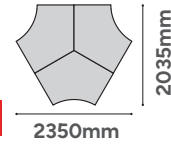

NEW

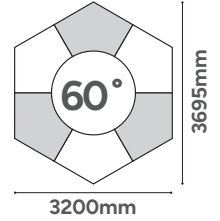

A

Fixed Height
ACTPENTA60

Height Adjustable (Mobile)
ACTPENTA60AW

5

TRINITY

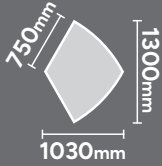

Fixed Height
ACTTRI

Height Adjustable (Mobile)
ACTTRIAW

10

QUARTER

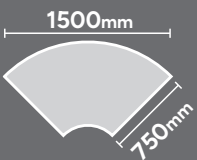

Fixed Height
ACTQUART

Height Adjustable (Mobile)
ACTQUARTAW

8

ARC

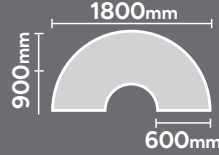

Fixed Height
ACTARC

Height Adjustable (Mobile)
ACTARCAW

"NO RATTLE, GUARANTEED!"



Acer Table Range

3

FAN

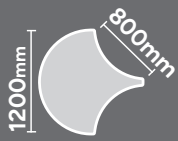

Fixed Height
ACTFAN

Height Adjustable (Mobile)
ACTFANAW

4

BONE

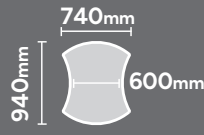

Fixed Height
ACTBONE

Height Adjustable (Mobile)
ACTBONEAW

6

STAR

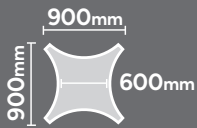

Fixed Height
ACTSTAR

Height Adjustable (Mobile)
ACTSTARAW

12

HELIX

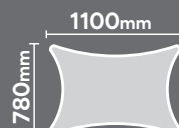

Fixed Height
ACTHELIX

Height Adjustable (Mobile)
ACTHELIXAW

13

AXIS

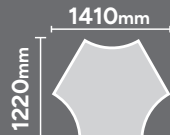

Fixed Height
ACTAXIS

Height Adjustable (Mobile)
ACTAXISAW



Tested to AS/NZS 4610.3
Education Tables

No Rattle,
Guaranteed



Tables

- 650mm high version – ideal for primary school

ECHO FLIP TABLE



- Tops**
- .FXOK
- Frames**
- .SB
 - .SV
 - .RC
 - .WH
 - .WH
 - .BK

- Adjustable length beam
- * Some colours avail.

Huge range of sizes & styles

TABLE HEIGHT	TOP SIZE	CODE
725mm	1500 x 750mm	ECH1575
	1800 x 750mm	ECH1875
650mm	1500 x 750mm	ECH1575L
	1800 x 750mm	ECH1875L



ACER FLIP TABLE

ACFPROUND



Erasable surfaces now available 1200mm dia. only
ACFPROUNDWB

- .WH
 - .SV
 - .OAK
- See pg.90



EXAMINER TRAPEZOID TABLE

EXTATRAP



*2 Tables pictured

- 1265W x 550D
- Diagonal width - 630mm
- Height options - 560, 625, 685, 725mm
- 18mm melamine top
- Powder coat steel frame

EXAMINER LECTURE DESK



SIZE	CODE
675W x 525D	EXLEDK0705
1125W x 450D	EXLEDK1104
1350W x 525D	EXLEDK1305

- E0 laminated top
- Available in a Range of Colours
- 4 Legged fixed height frame
- Polished bullnose edge
- No drawer



QUADRIC FOLD-UP EXAM TABLE

QDFTB0805



- Trolley holds 16 tables

- H730 x W800 x D550mm
- 18mm E-Zero top
- Folding frame



7 YEAR WARRANTY

STAX EXAM TABLE

STAXTABLEB



- H720 x W750 x D700mm
- 12mm MDF Top (E1) with heavy duty slimline rod frame
- Available in Diamonds top with Pearl Silver powdercoat frame or Oak top with black frame
- Stackable up to 25 high on a trolley

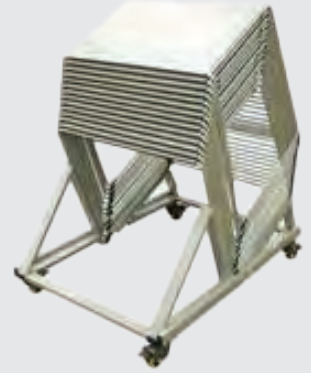

Stax Trolley
STAXTROLLEY

3 YEAR WARRANTY



LEXIE FOLDING EXAM TABLE

LEXFTB7505.GY



- 725H x 750W x 500D
- Lightweight and durable
- Foldable legs for easy storage
- Solid steel frame
- Tough ABS top with built in pencil tray

Lexie Trolley

- Fits up to 18 Lexie Folding Exam Tables

LEXFTBTR18



UPTOWN GASLIFT TABLE

UPTB0605

NEW



GAS LIFT!

- 600w x 550d
- Height Range 750-1150mm
- Lift capacity 5kg
- Total load capacity 40kg
- Tablet groove
- Drink holder
- Lockable castors

Tops

- .WH
- .OAK

Base

- .WH
- .BK

DESK BUGGY-HEIGHT ADJUST

DKBUG01.WH



- Strong one-piece castor base
- Sit to stand adjustability
- Large twin-wheel castors (2 lockable)
- Sealed gas cylinder
- Device storage slot, suitable for tablet or phone
- Contoured top with round edge to prevent chipping
- Easy one hand gas lift operation
- Splayed base to give you plenty of space for your feet
- Top Size: 715 x 475mm
- Height Range: 736 x 1050mm

10 YEAR WARRANTY

Island Table System

Island Tables bring people together whilst setting them apart

Ideal for meetings, collaboration and individual work in libraries, staff rooms, breakout spaces and administration. Available in 3 heights (720mm, 900mm, 1050mm) that can be mixed and matched to keep things interesting.



ISLAND LINEA TABLE

The Island Linea Table is ideal for meetings, collaboration and individual work in libraries and staff rooms.

PRODUCT	CODE	SIZE (mm)
Island Linea Table	ISLTB2412	W2400 x D1200 x H720
Rondo Ottomans	PDRON005	W470 x D470 x H425



ISLAND LINEA LOW BENCH

The standing height Island Linea Low Bench opens the communication lines to creative thinking. Seats 8.

PRODUCT	CODE	SIZE (mm)
Island Linea Low Bench	BEL2412	W2400 x D1200 x H900

*Chairs not included



ISLAND CURVE TABLE

The Island Curve Table is ideal for meetings and collaboration. Butt together or use against a wall or lounge.

PRODUCT	CODE	SIZE (mm)
Island Curve Table	ISLTB1212	W1200 x D1200 x H720
Rondo Ottomans	PDROND05	W470 x D470 x H425
Nova Lounge	NOVA02L	W1200 x D680 x H745
Pebble Table	PEBB400	W400 x D400 x H650



ISLAND CURVE LOW BENCH

The standing height Island Curve Low Bench can be used against a wall or butted together for meetings with height.

PRODUCT	CODE	SIZE (mm)
Island Curve Low Bench	ISLBEL1212	W1200 x D1200 x H900

*Chairs not included



ISLAND TECTONIC

The Island Tectonic setting with its dual height offers variety in working heights. Ideal for collaborating or break out.

PRODUCT	CODE	SIZE (mm)
Island Curve Table	ISLTB1212	W1200 x D1200 x H720
Island Curve Low Bench	ISLBEL1212	W1200 x D1200 x H900

*Chairs not included



PANGEA + MARUCHI

The Island Curve low table can be divided by a Planta unit and surrounded by Maruchi Stools.

PRODUCT	CODE	SIZE (mm)
2 x Island Curve Table	ISLTB1212	W1200 x D1200 x H720
Planta 1200	PLHIGH1200	W1200 x D300 x H800
Maruchi Stool	MARST490	D330 x H490

*Plants not included

Creative Seating

BEAN FREE CLOUD CHAIRS



Small
62cm x 62cm x 72cm H
Suitable for Pre-school / Lower Primary
TCXCCS

Medium
97cm x 91cm x 71cm H
Suitable for Primary
TCXCCM

Colours



Z-FLEX DESK

Versatile work surface for writing or using laptops on the floor, in a chair, or outdoors.

Flexible solution for classrooms and home schooling

- students can take notes and work on the go.

Product Dimensions: 60L x 37W x 30Hcm
Polyurethane. Available in Blue, Green & Red.
TCXZFLEX



EZSOFT CHAIR



Each seat is 55.5cm (W)
Available in Red, Blue, Green, and Orange
TCXEZSC

Reclines and folds flat for easy storage



CALMING CANOE

Provides the right amount of pressure to boost sensory integration skills and develop motor planning
Particularly appropriate for those with Sensory Processing Disorder (SPD)
Requires inflation
178cmL x 80cmW x 48cmH



LAP TRAY TABLE

Pack of 4

- H200 x W580 x D300mm
- Sturdy and easy to clean
- Storage compartments
- Stackable
- Choose set of 4 in one colour (Red, Primary Blue or Lime Green), Bright Mix (Purple, Red, Lime Green, Primary Blue) or Pastel Mix (Teal, Magenta, Lime Green, Light Blue)



DIP ROCKER CHAIRS

Weight per chair: 23kg
Each Seat:
39cm (L), 45cm (W), 36cm (H).

Set of 4
TCXDRC4



Available in 4 colours



FOAMY RANGE - BEAN FREE BAGS



Chair Bag
FOAMYCB01
• 900W x 600D x 700H

Filled with comfort foam. A unique custom blend of high quality foams. This unique filling outperforms regular polystyrene beanbags in terms of comfort and durability, but most importantly, the filling is safe for children.

- Anti-bacterial • Anti-microbial
- Fully assembled



See pg. 43



Tear Drop
FOAMYTD01
• 750W x 750D



Crash Pad
FOAMYCP01
• 1300W x 1700D



Party Pod
FOAMYPP01
• 1800W x 1200D

THERAPY PEANUT BALL

Builds strength, flexibility and balance with a positive vestibular input
Ridged surface provides extra grip
Pthalate and BPA free
80cm Long with 40cm diameter ball ends
TCPB



SAFEHOOK

With a recessed design, the Safehook is the perfect option for a safe bag hook unit with not protruding hooks. The Safehook is designed for schools with a high level of wear and tear ideal for heavy traffic.

- 177H x 480W x 45Dmm
- 3 colours - Beige, Black and White
- 4 hooks per unit
- Safe recessed design with no protruding hooks
- Designed for schools
- Flame retardant
- UV Stabilised allowing for internal or external application
- Wall fixing kit and instructions included with each unit



CODE SAFEHOOK



A HOOK THAT IS SAFE, STRONG AND LOOKS GOOD.



Habitat Range

The Habitat Modular Lounge creates collaborative work settings designed to support small groups of students, providing a safe space to relax, restore or refocus.



HABITAT D1
HABITATD1

- Feel the embrace of the Habitat D1 as you break away for group based activities or browse from the book shelves.
- W3540 x D2295 x SH450



HABITAT D2
HABITATD2

- Habitat D2 is an amphitheatre style information hub with two levels of seating. 900 H.
- W3540 x D1770 x SH450
- Stools not included



HABITAT D3
HABITATD3

- Habitat D3 creates a soft hideaway with curved lines and modern appeal for open plan spaces.
- W4220 x D1604 x SH450
- Pebble table not included (PEBB400)



HABITAT D3
HABITATD3

- The Habitat Cove is a cosy, inclusive and friendly setting for collaborative meetings with breakout seating beyond.
- W4785 x D3540 x SH450
- Circo 600 ottoman not included (PDCIRC06)
- Discus table not included (DISCTB1000/1200)



HABITAT BOOMERANG
HABITATBOOM

- The Habitat Boomerang transforms open spaces, learning commons and libraries, creating a place for respite.
- W4220 x D1604 x SH450
- Table not included



HABITAT STREAM
HABITATSTREAM

- Let learning flow with the Habitat Stream, designed to host small casual meetings, breakout activities and group activity.
- W4572 x D1780 x SH450
- Rondo ottoman not included (PDRON005)
- Discus table not included (DISCTB1000/1200)

Habitat Range



HABITAT MEADOW
HABITATMEADOW

- This informal yet comfortable Habitat Meadow lounge setting feels right at home in any school breakout zone.
- W2250 x D1050 x SH450
- Pebble table not included (PEBB400)



HABITAT HEATH
HABITATHEATH

- Carve out some room for comfort. The gentle curved configuration of the Habitat Heath is a space defining sofa.
- W2812 x D1415 x SH450

Habitat offers lounge, storage and worksurface components that are structured to suit your space

*Habitat Settings are not designed to be reconfigured/moved. Mobile options also available \$POA (Habitat Flexi see pg. 42)



Meadow



Field

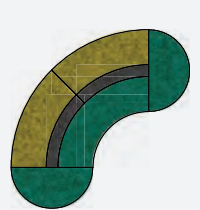

Heath

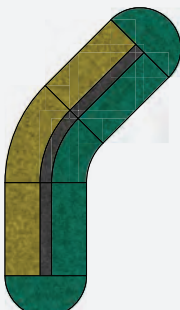

Boomerang

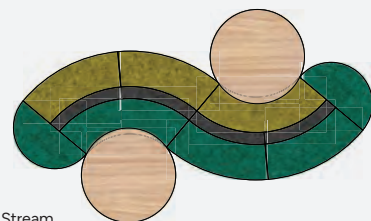

Stream

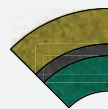

HABBB135SE



HABSS135SE+
HABSS135BE

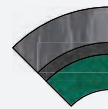

HABSS135SE+
HABSS135BC



HABDEND

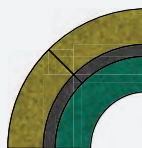

HABBBCVSE



HABSSCVSE+
HABSSCVBE

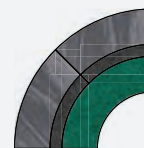

HABSSCVSE+
HABSSCVBC



HABSSCVSE



HABBBSTSE



HABSSSTSE+
HABSSSTBE



HABSSSTSE+
HABSSSTBC

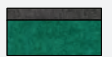

HABSSSTSE

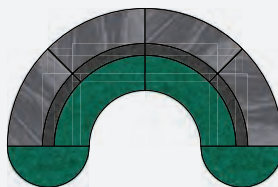

Den (HD1) [Lounge/Bookcase]

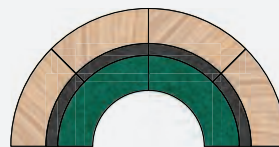

Den (HD2) [Lounge/Bench]

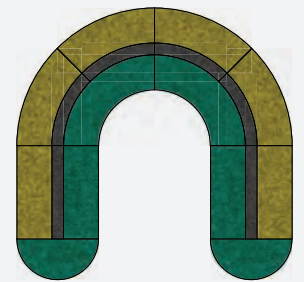

Horseshoe

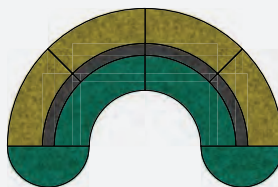

Den (HD3) [Lounge/Lounge]

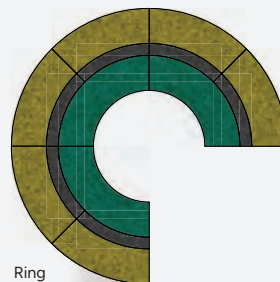

Ring

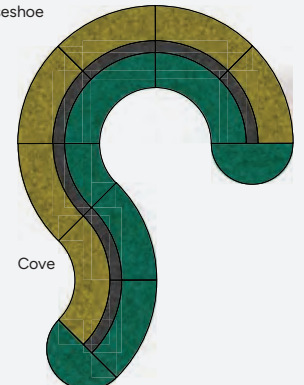

Cove

Habitat Range



Ask about Habitat Flexi available with castors and new low height bench (750mm H)



Flexi version:
3 x HABSSEVSE+3 x HABSSCVBC

In The Round

Twist...Curve...Shape.

With "In the Round" you can create a multitude of configurations. Perfect for libraries and collaboration spaces. Popular settings include C-shape and snake shape.

IN THE ROUND

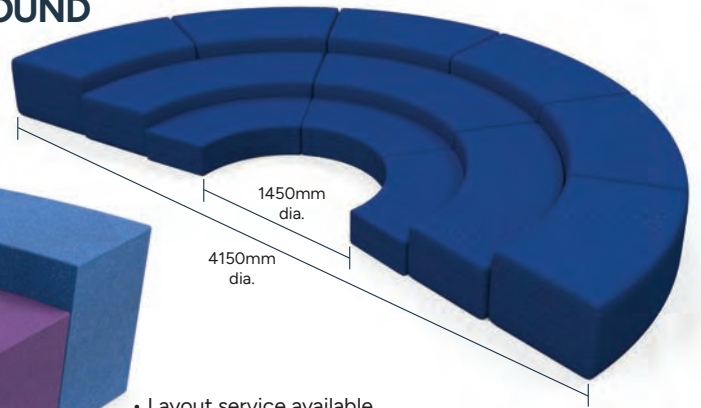

- Layout service available
- Box construction with 80mm and 35mm glides
- Inner High - 600H x 450D ITRINHIG01 (not pictured)
- Inner Low - 300H x 450D ITRINLOW01
- Middle - 450H x 450D ITRMIDMED01
- Outer High - 600H x 450D (Set of 2) ITROUTHIG02
- Outer Low - 300H x 450D (Set of 2) ITROUTLOW02 (not pictured)

TRAPEZOID OTTOMAN

TRAP900L/R

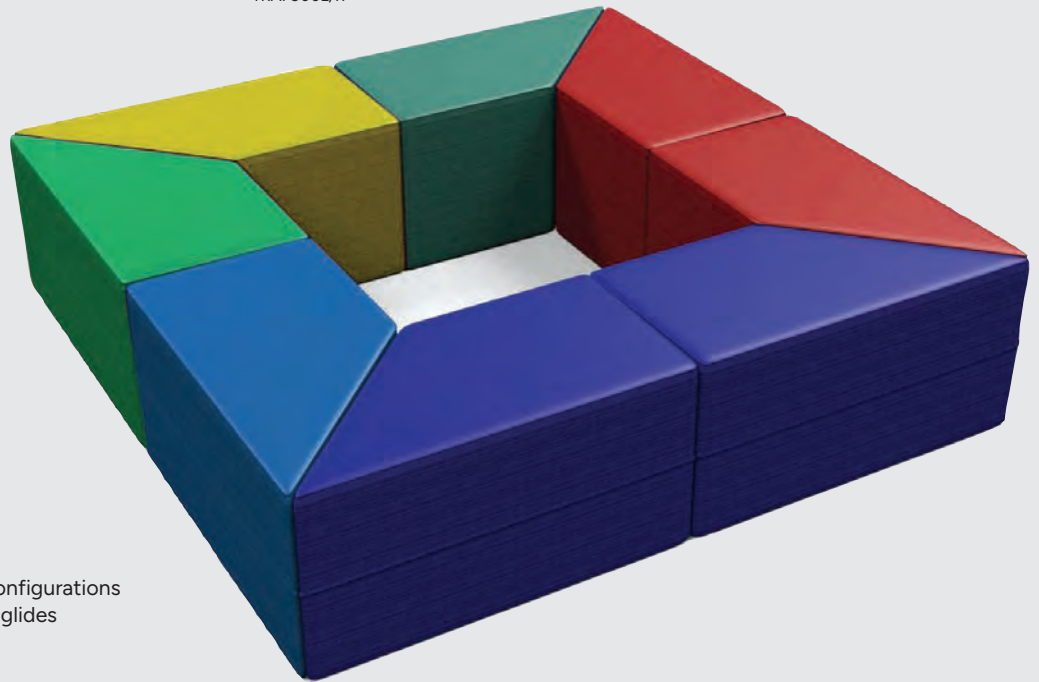
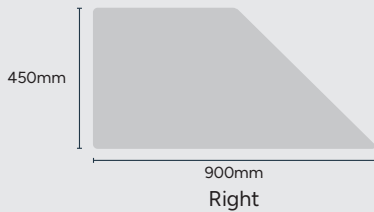
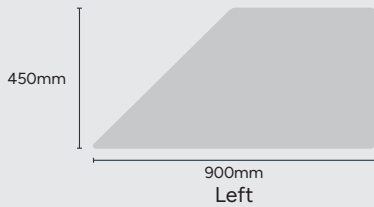

- 900W x 450D x 450H
- Designed to enable straight line and zig-zag configurations
- Full foam on 18mm plywood base with 35mm glides

Vinyl Upholstery - Warwick Lustrell Charisma

Visit: <https://www.warwick.com.au/collections/lustrell-charisma-2/>



Fabric Upholstery - Warwick Beachcomber

Visit: <https://www.warwick.com.au/collections/beachcomber/>



*Colours are indicative only.

Rainbow Modular Soft-Seating



• Shaped Back



Shown in Warwick Dolly fabric (Citron & Mink) (\$POA)

- Smart design – 4 simple pieces
- Solid ply construction
- Heavy duty locking castors
- Easily reconfigured
- Priced in Category 1 fabric
- 100s of fabric options (\$POA)
- Seat height 450 mm | back height 750 mm

Modular & mobile

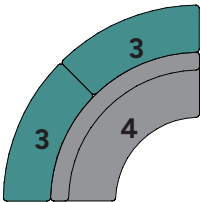
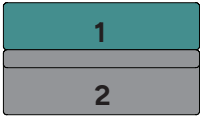

BACK STYLE	SHAPE	CODE
NO BACK	1 - Straight	RAIN1SNB
	3 - Curve	RAIN3CNB
SQUARE BACK	2 - Straight	RAIN2SWB
	4 - Curve	RAIN4CWB
SHAPED BACK	2 - Straight	RAIN5SSB
	4 - Curve	RAIN6SSB



A 3pce – 1870W x 1870D



B 2pce – 1872W x 1070D



C 5 pce - 3743W x 1870D



D 9 pce - 6434W x 1850D



E 10 pce - 3742W x 3744D

MANY Colours available POA

AUSTRALIAN MADE

See page 51



F 14 pce - 5614W x 3744D



G 11pce - 3742W x 3744D

Rainbow Modular Soft-Seating



Shape Ottomans

An endless array of seating for informal learning and breakout areas

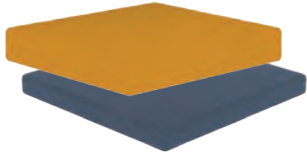

LILYPAD SQUARE
PDLPSQUARE

- The Lilypad Square seat pad can be housed in Cubo or Rubix storage units.
- W375 x D375 x H50



LILYPAD PETAL CUSHION
PDLPPET

- The Lilypad Leaf is the perfect place to stop and enjoy a story or group activity.
- D480 x H80
- PDLPPETTROLLEY **Lilypad Petal Trolley**



LILYPAD ROUND

- Who's ready for a story? Our Lilypad Round Cushions are made for storytime.
- PDLPCENT **Lilypad Leaf** D600 x H80
- PDLPTROLLEY **Round Trolley** D690 x H1200



PETAL OTTOMAN
PDFLOWPET

- The beautiful petal ottoman with its soft, curved shape fans around tables.
- D460 x H425



RONDO
PDROND05

- Light enough to pull up and join the group, Rondo is ideal for occasional seating.
- D470 x H425



CIRCO

- The Circo Ottoman is available in 3 sizes to create fun circular seating pods anywhere.
- PDCIRC06 D600 x H425
- PDCIRC09 D900 x H425
- PDCIRC12 D1200 x H425



BAGEL
PDBAGEL

- Flexible, comfortable and versatile, Bagel is the modular ottoman for small spaces.
- D1400 x H425



FLOWER
PDFLOWER

- This collection of 6 ottomans will help work bloom. Mix and match colours available.
- D1300 x H425



SUNFLOWER
PDSUNFLOWER

- The 8 piece Sunflower is a well loved addition to any large breakout space. Mix and Match.
- D1620 x H425



ELEMENTS® TRIANGLE OTTOMAN
ELETRIOT

- Cute and comfy, our angular Elements Triangles are small in size, big in appeal.
- W680 x D590 x H450



CUBEE
PDCUBE

- Convenient to slide where needed, Cubee provides fun casual seating on the go.
- W420 x D420 x H425



ARCADIA OTTOMAN
ARCA01B

- Arcadia combines durability and style. With a plush foam seat for a cosy experience.
- W670 x D550 x H440

Shape Ottomans

VE Fabric Colours

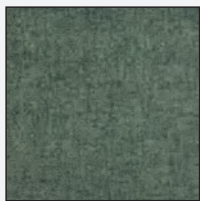

VE Amazon



VE Fern



VE Moss



VE Wattle



VE Ochre



VE Persian



VE Fox



VE Slate



VE Peat



VE Navy

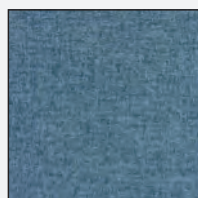

VE Abyss



VE Oasis



HABITAT LINEA
HABSTOT

- The Habitat Linea Ottoman is just the right size for breakout in nooks or against walls.
- W1200 x D450 x H450



HABITAT CURVE
HABCVOT

- Habitat Curve can be configured to create a unique seating solution for collaboration.
- W1650 x D660 x H450

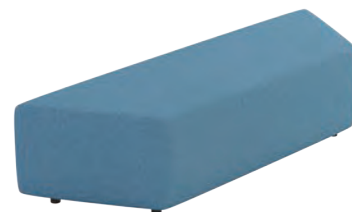

ELEMENTS® TRAPEZOID

- The Trapezium ottoman allows you to spread out and relax on interesting shapes.
- ELETRAP02B **Small** W1370 x D600 x H450
- ELETRAP03B **Large** W2075 x D600 x H450



HABITAT D END OTTOMAN
HABDEND

- The Habitat D End sits neatly at the end of lounges to create a soft curve or circle.
- W1050 x D525 x H450



ELEMENTS® HEXAGON
ELEHEXOT

- Breakout spaces in need of comfort? The Hexagon ottoman is just the piece.
- W1380 x D1200 x H450



PEBBLE OTTOMANS

- Lightweight yet robust, these items can easily be repositioned to add seating.
- PEBBSMALL D450 x H390
- PEBBMEDIUM D650 x H390
- PEBBLARGE D850 x H390

Brissie Ottomans

FOAMY FLIP OTTOMAN



See pg. 43

- Low FOAMFLIP350
450W x 400D x 350H
- High FOAMFLIP450
450W x 400D x 450H
- Full high density foam block

BRISSIE SEMI CIRCLE OTTOMAN



See pg. 43

- Box construction with 80mm and 35mm glides
- Small Low BRISSEM0945
450H x 900mm dia.
- Small High BRISSEM0960
600H x 900mm dia.
- Large Low BRISSEM1245
450H x 1200mm dia.
- Large High BRISSEM12960
600H x 1200mm dia.

FOAMY SEATPADS & CADDY



See pg. 43

- Pads FOAMSP45/60
- 450dia. x 50mm thick
- 600dia. x 90mm thick
- High density foam
- Caddy FOAMSPCAD450/600
- 650W holds 12 x 450dia seatpads
- 1010W holds 12 x 600dia seatpads

FOAMY NINJA BLOCKS

Students can let their imagination run wild creating their own environment. Use as seats, work surfaces or as building blocks.

- Full high density foam block
- Very versatile
- Minimum 6 blocks per purchase
- Available in many vinyl colours and fabrics available
- Small: 150H x 300D x 600Lmm NINJA06
- Large: 150H x 300D x 1200Lmm NINJA12



See pg. 43

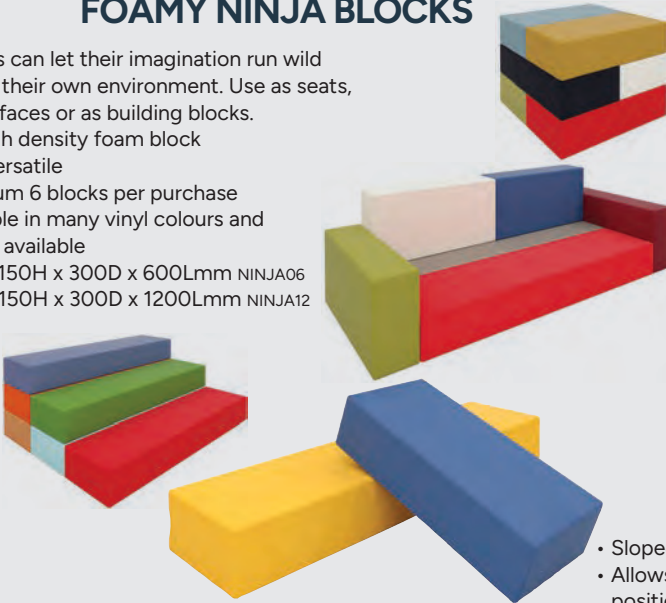

FOAMY TILT-TOP OTTOMAN

FOAMTILT450



See pg. 43

- Sloped top (10 degrees)
- Allows students a more comfortable position whilst maintaining correct posture
- 450W x 450D x 450H
- 10% Angle on top
- Full high density foam block

BURRA OTTOMAN

- Rectangular size options:
900W x 450H mm BUR9045
1350W x 450H mm BUR1350



- Square size options:
450W x 450H mm BUR4545
600W x 600H mm BUR6060



See pg. 43

- Box construction, high density foam

PUZZLE OTTOMAN



PUZZO1

- Easily build your own puzzle ottoman by placing pieces together in various ways to suit your unique space.
- Size: 450H x 820W x 580D mm
- Available in easy to clean vinyl in Blue, Green, Red and Yellow



Brissie Ottomans

SIT DRUM OTTOMAN
BRIS450RD



- 450H x 450mm dia.
- Full foam on 18mm plywood base with 35mm glides



STAY CUBE OTTOMAN
BRIS450SQ



- 450H x 450W x 450D
- Full foam on 18mm plywood base with 35mm glides



CLOVER OTTOMAN
BRISCLOVER



- 450H x 850mm dia.
- Box construction, high density foam



PAC OTTOMAN
BRISCLOVER



- 450H x 700mm dia.
- Full foam on 18mm plywood base with 35mm glides



PIE OTTOMAN
BRISPIE



- 450H x 485mm rad.
- Box construction, high density foam
- Table separate \$POA



TRIANGLE OTTOMAN
BRISRI600



- 450H x 600W x 600D
- Full foam on 18mm plywood base with 35mm glides



WAVE OTTOMAN
BRISWAVE



- 450H x 1500W x 600D
- Box construction, high density foam



BOX OTTOMAN



- Box construction, high density foam

Size	Code
1200W x 450D x 450H	BRIS1245
600W x 600D x 450H	BRIS0660
1500W x 600D x 450H	BRIS1560
1800W x 600D x 450H	BRIS1860
2100W x 600D x 450H	BRIS2160
1800W x 750D x 450H	BRIS1875



ROUND OTTOMAN



- Box construction, high density foam

Size	Code
450H x 600mm dia.	BRIS-600RD
450H x 900mm dia.	BRIS-900RD



ROBOT OTTOMAN



- Box construction, high density foam

Size	Code
450H x 500mm dia.	BRIS-RBT500
450H x 750mm dia.	BRIS-RBT750
450H x 900mm dia.	BRIS-RBT900



QUARTER OTTOMAN



- Box construction, high density foam

Size	Code
1800W x 450D x 450 dia.	BRISQTR450
2400W x 600D x 450 dia.	BRISQTR600



PEBBLE OTTOMAN



- Full foam on 18mm plywood base with 35mm glides

Size	Code
450H x 450mm dia.	BRISPEB450
450H x 600mm dia.	BRISPEB600
450H x 900mm dia.	BRISPEB900
450H x 1200mm dia.	BRISPEB1200



Sunrise Lounge System



Express your creativity

Customise your Sunrise space to reflect your imagination. The creative options are endless.

Free and flowing

The open, unrestricted design of Sunrise allows you to relax in optimum comfort.

Firm comfort

With large seats and back cushions, timber legs and a steel frame, Sunrise is both comfortable and durable.



SRISE01B

SRISE01L

SRISE01LA

SRISE02L

SRISE02LA

SRISE03L

Linear – extend at will

The modules allow you to design the ideal lounge configuration to suit your requirements.

Seat	No Arms - 750H x 750D		With Arms - 750H x 750D		Bench - 420H x 750D		Booth - 1400H x 750D	
	Length mm	Code	Length mm	Code	Length mm	Code	Length mm	Code
1	650	SRISE01L	890	SRISE01LA	650	SRISE01B	710	SRISE01LB
2	1300	SRISE02L	1540	SRISE02LA	1300	SRISE02B	1360	SRISE02LB
3	1950	SRISE03L	2190	SRISE03LA	1950	SRISE03B	2010	SRISE03LB

Flax Fabric Colours



Quilted Fabric Colours (Screens)

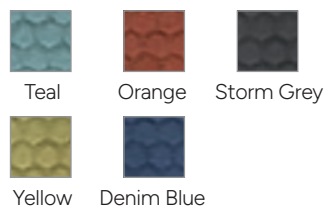

SRISE015LBTA



SRISE02LB

The beauty is in the detail

The unique Sunrise thread decoration brings spirit to the whole design. The insertable and moveable shared armrest enables arm support wherever you sit. Topped off with metal legs and a coffee table, the Sunrise style exudes quality.



Benchmark Lounge System

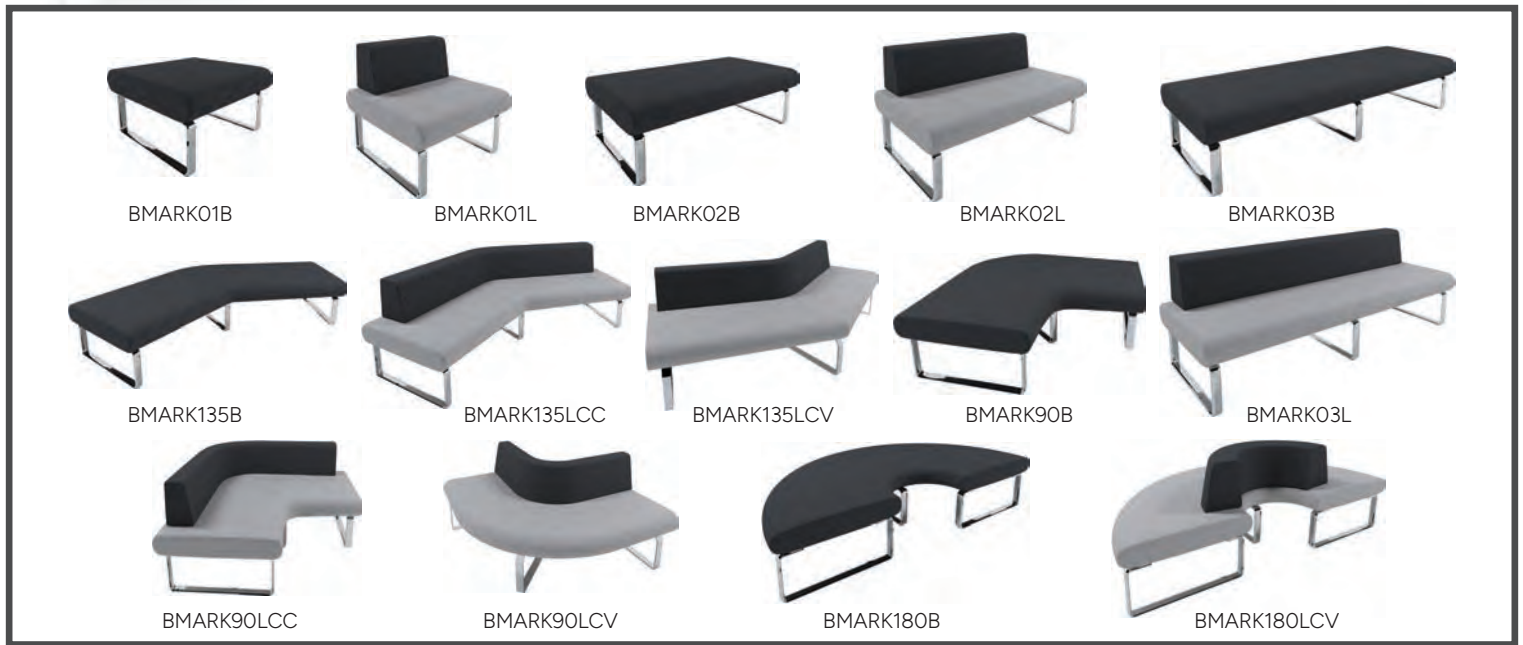

Easily combines to form a myriad of shapes



Seat	Type	Height mm	Depth mm	Length mm	Code
1	Bench	420	775	760	BMARK01B
1	Lounge	715	775	760	BMARK01L
2	Lounge	715	775	1350	BMARK02L
3	Lounge	715	775	2060	BMARK03L

*Black Vinyl in stock



Fonzetta, Lion & Tasmania Lounges



FONZETTA MOBILE BENCH SEAT

FONZ02

- Dimensions: H1100 x W1520 x D600mm
- Seat height: 450mm
- Standard with E-Zero, Silver Haze melamine carcass, upholstered in Warwick Rave
- Other fabrics available (\$POA)
- 6 lockable castors
- Inset – 1500 x 750mm Luna table (dual base) TPR1575.XX + 2 X LUNA72.CR



See pg. 43



LION LOUNGE CHAIR

LION01



- 850H x 570W x 850Dmm
- Priced in Rave fabric or Lustrell vinyl
- Other fabrics available (\$POA)



See pg. 43

7 YEAR WARRANTY



- Dunlop seat foam
- No springs – black seat webbing (10 year commercial warranty)
- Strong timber frame
- Matte black Borsari legs (170mmH)
- Available in single, double or triple seater

TASMANIA LOUNGES

TASMXX

Code	Description	Size
TASM01	Tasmania Lounge Single Seater	550W X 800D X 800H (SEAT 480H)
TASM01A	Tasmania Lounge Single Seater w/Arms	790W X 800D X 800H (SEAT 480H)
TASM02	Tasmania Lounge 2 Seater	1100W X 800D X 800H (SEAT 480H)
TASM02A	Tasmania Lounge 2 Seater w/Arms	1340W X 800D X 800H (SEAT 480H))
TASM025	Tasmania Lounge 2.5 Seater	1570W X 800D X 800H (SEAT 480H)
TASM025A	Tasmania Lounge 2.5 Seater w/Arms	11810W X 800D X 800H (SEAT 480H)
TASM03	Tasmania Lounge 3 Seater	1650W X 800D X 800H (SEAT 480H)
TASM03A	Tasmania Lounge 3 Seater w/Arms	1890W X 800D X 800H (SEAT 480H)

Flight & Wing



Flight Lounge



Wing Lounge



With acoustic qualities, these high back lounges are perfect for any breakout area where privacy is a must. Used for meeting or quiet time. Australian made with high density foams.

Seat	Size (mm)	Flight Code	Wing Code
1	900W x 750D x 1350H	FLIGH01	WING01
2	1500W x 750D x 1350H	FLIGH02	WING02
3	2000W x 750D x 1350H	FLIGH03	WING03

5 YEAR WARRANTY



See pg. 43

The "Q" & Chai Lounges



Chai
• Rounded design

The "Q"
• Square design
No Arms



The "Q"
• Square design
With Arms

Add an aesthetic touch to your office waiting room with this contemporary lounge range. 100% Australian made, locally sourced Australian timbers accompanied with Australian high quality foams.

Seat	No Arms – H840 x D700 mm			With Arms – H860 x D750 mm		
	Length (mm)	The Q Code	Chai Code	Length (mm)	The Q Code	Chai Code
1	560	THEQ01	CHAI01	730	THEQ01A	CHAI01A
2	1070	THEQ02	CHAI02	1320	THEQ02A	CHAI02A
3	1515	THEQ03	CHAI03	1750	THEQ03A*	CHAI03A*

5 YEAR WARRANTY



See pg. 43



Origami Modular Lounge System

Reconfigurable for flexible spaces



ORIGAMI SUMI

- Sumi is ideal for foyers, libraries, staff rooms and admin areas to create a comfortable place to seek respite.
- W2250 x D750 x SH450

PRODUCT	CODE	SIZE (mm)
Origami Single Lounge	1 x ORIG01LC	W750 x D750 x SH450
Origami Two Seat Half Lounge	1 x ORIG02LL	W1500 x D750 x SH450



ORIGAMI NESUTO

- Origami Nesuto helps to zone space whilst offering a place to unwind, socialise or settle in to read or work.
- W3600 x D1500 x SH450
- Plants not included

PRODUCT	CODE	SIZE (mm)
Origami Single Lounge	4 x ORIG01LC	W750 x D750 x SH450
Origami Two Seat Lounge	2 x ORIG02L	W750x D750 x H450
Planta 1500	2 x PLHIGH1500	W1500 x D300 x H800



ORIGAMI OKORU

- The Origami Okoru setting creates a space for casual meetings, teamwork, private study or socialisation.
- W4800 x D1500 x SH450
- Plants not include

PRODUCT	CODE	SIZE (mm)
Origami Two Seat Lounge	4 x ORIG02L	W1500 x D750 x SH450
Pebble	2 x PEBB400	W400/350 x D400 x H650
Planta 1500	1 x PLHIGH1500	W1500 x D300 x H800



ORIGAMI BOTO

- Use Origami Boto at your learning facility in open floor plan spaces, libraries and senior spaces. Add a Pebble Table!
- W3000 x D1500 x SH450

PRODUCT	CODE	SIZE (mm)
Origami Two Seat Lounge	2 x ORIG02L	W1500 x D750 x SH450
Origami Fan Ottoman	4 x ORIG01FAN	W750x D750 x H450
Pebble	1 x PEBB400	W400/350 x D400 x H650



ORIGAMI ORU

- Oru invites you to take a seat whilst waiting in reception. Ideal for corner spaces but easily reconfigured.
- W2250 x D2250 x SH450

PRODUCT	CODE	SIZE (mm)
Origami Two Seat Lounge	2 x ORIG02L	W1500x D750 x SH450
Origami Single Lounge	1 x ORIG01LC	W750 x D750 x SH450

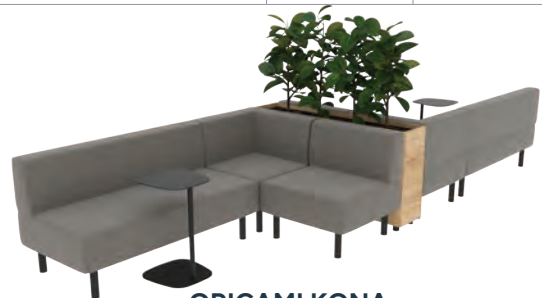

ORIGAMI KONA

- Origami Kona creates space for lounging, conversing and meeting with its design inspiring creativity and connection.
- W4800 x D1500 x SH450
- Plants not included

PRODUCT	CODE	SIZE (mm)
Origami Single Lounge	2 x ORIG01LC	W750 x D750 x SH450
Origami Two Seat Lounge	2 x ORIG02L	W1500x D750 x SH450
Origami Single Seat Lounge	2 x ORIG01L	W7500 x D750 x SH450
Pebble	2 x PEBB400	W400/350 x D400 x H650
Planta 1500	1 x PLHIGH1500	W1500 x D300 x H800

ORIGAMI OTTOMANS



Origami Square Ottoman
ORIG01B

- Small, stylish and comfortable, the generously cushioned Origami Square Ottoman is a great addition to any space
- 750W x 750D x 450H

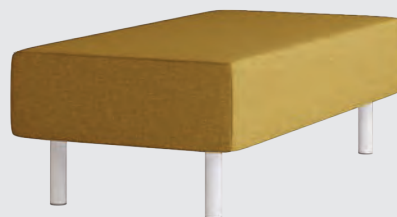

Origami Bench Ottoman
ORIG02B

- The Origami Bench Ottoman is ideal for breakout areas, libraries, foyers or anywhere you want to soften your space
- 1500W x 750D x 450H



Origami Fan Ottoman
ORIG01FAN

- Our Origami Fan Ottoman features a clever shape ideal for softening corners, creating pies or as an add-on
- 750W x 750D x 450H

MANY
Colours
available
POA

See
pg. 90

Origami Modular Lounge System

MANY
Colours
available
POA

See
pg. 90



ORIGAMI SINGLE SEAT LOUNGE
ORIG01L

- The Origami Lounge Chair offers seating comfort at its best. The modular design allows you to create settings to suit.
- W750 x D750 x SH450



ORIGAMI SINGLE LOUNGE
ORIG01LC

- The Origami Single Lounge provides endless options for modular seating, use it to create L or U shaped settings.
- W750 x D750 x SH450



ORIGAMI TWO SEAT LOUNGE
ORIG02L

- The Origami Two Seat Lounge is a modular, versatile and comfortable piece that can be used just about anywhere you need it.
- W1500 x D750 x SH450



ORIGAMI TWO SEAT HALF LOUNGE

- The Origami Half Sofa, half ottoman can be used just about anywhere to add softness and colour.
- ORIG02LL **LH Lounge** W1500 x D750 x SH450
- ORIG02LR **RH Lounge** W1500 x D750 x SH450



ORIGAMI SINGLE BOOTH
ORIGBTH01

- The acoustic absorption of the Origami Sofa Booth reduces external noise making it ideal for private study.
- W850 x D800 x SH450



ORIGAMI TWO SEAT BOOTH
ORIGBTH02

- The acoustic absorption of the Origami Sofa Double Booth reduces external noise making it ideal for private gatherings.
- D800 x SH450

ORIGAMI COFFEE TABLES



Origami Square Coffee Table
ORIGCTS

- The Origami modular lounge system includes a matching table with under frame storage for a modern touch
- 750W x 750D x 450H



Origami Tera Coffee Table
ORIGCTO

- The Origami Tera Table can be used independently, in a corner or on the end of Origami Modular Lounges
- 750W x 750D x 450H



Origami Fan Coffee Table
ORIGCTFAN

- The Origami Fan Table is ideal for use at the end of Origami Lounges to create a soft, curved end
- 750W x 750D x 450H

Elements Modular Lounge

The Elements® Range is denoted by an angular profile for defined spaces



ELEMENTS® F1

- Feel the embrace of Elements F1 as you break away for group based activities or retreat for a spot of reflection and focus.
- W3300 x D2798 x SH450

PRODUCT	CODE	SIZE (mm)
Elements Trapezoid Lounge	4 x ELETRAP02L	W1370 x D600 x SH450
Bookcase	4 x ELETRAP02BC	W1827 x D450 x H720



ELEMENTS® ESKER

- Create a sense of open plan privacy with the Elements Esker. Designed for small, casual meetings, breakout and study.
- W3460 x D3600 x SH450

PRODUCT	CODE	SIZE (mm)
Elements Trapezoid Lounge	6 x ELETRAP03L	W2075 x D600 x SH450



ELEMENTS® F2

- With its external benches, Elements F2 creates a soft hideaway with angled lines and modern appeal for open spaces.
- W3300 x D2798 x SH450
- Chairs not included

PRODUCT	CODE	SIZE (mm)
Elements Trapezoid Lounge	4 x ELETRAP02L	W1370 x D600 x SH450
Bench	4 x ELETRAP02BE	W1386 x D450 x H720



ELEMENTS® LYNX

- Create dynamic work areas with the Elements Lynx setting. Includes 1x Hex ottoman and 4x Large Trapezoid Lounges.
- W3600 x D2770 x SH450

PRODUCT	CODE	SIZE (mm)
Elements Trapezoid Lounge	4 x ELETRAP03L	W2075 x D600 x SH450
Elements Hexagon Ottoman	1 x ELEHEXOT	W1380 x D1200 x H450



ELEMENTS® F3

- With its upholstered back, Elements F3 creates a focussed group space. iDisc Hex reflects the angular appeal.
- W2400 x D2070 x SH450

PRODUCT	CODE	SIZE (mm)
Elements Trapezoid Lounge	4 x ELETRAP02L	W1370 x D600 x SH450
Hexagon Discus Table	1 x DISCTBHEX12	W1386 x D450 x H720



ELEMENTS® PINGO

- The Elements Pingo setting combines seating with resource storage. Angular design softened by quality upholstery.
- W6810 x D3300 x SH450

PRODUCT	CODE	SIZE (mm)
Elements Trapezoid Lounge	6 x ELETRAP02L	W1370 x D600 x SH450
Bookcase	6 x ELETRAP02BC	W1827 x D450 x H720
Hexagon Discus Table	2 x DISCTBHEX12	W1386 x D450 x H720

VE E0 Melamine Colours

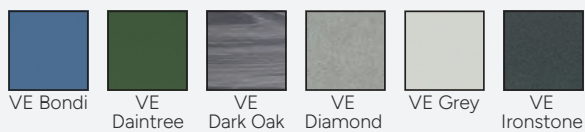

VE Bondi VE Daintree VE Dark Oak VE Diamond VE Grey VE Ironstone



VE Light Oak VE Natural Oak VE Pindan VE Storm VE White VE Zincworks VE Writable

VE Fabric Colours



VE Amazon VE Fern VE Moss VE Wattle VE Ochre VE Persian



VE Fox VE Slate VE Peat VE Navy VE Abyss VE Oasis

7 YEAR WARRANTY

MANY Colours available POA

Elements Modular Lounge



ELEMENTS® TRAPEZOID LOUNGE
ELETRAP02L

- The comfortable Elements Earth Trapezium Sofa allows you to create interesting shapes with its angular design.
- W1370 x D600 x SH450



ELEMENTS® TRAPEZOID LOUNGE
ELETRAP03L

- Soften a space with the plush Elements Earth Trapezoid sofa, big on comfort with a variety of ways to configure.
- W2075 x D600 x SH450



ELEMENTS® DIAMOND OTTOMAN
ELELIAOT

- The Elements Earth Diamond, with its angular design is an interesting addition to any space needing seated comfort.
- W1100 x D600 x H450



ELEMENTS® TRIANGLE OTTOMAN
ELETRIOT

- Cute and comfy, our angular Elements Earth Triangles are small in size yet big in appeal and comfort.
- W680 x D590 x H450



ELEMENTS® TRAPEZOID OTTOMAN
ELETRAP02B

- The small angular Trapezoid ottoman has lots of charm. Configure it with other pieces from the range or pair them up.
- W1370 x D600 x H450



ELEMENTS® TRAPEZOID OTTOMAN
ELETRAP03B

- The large Trapezoid ottoman allows you to spread out, be in against a wall or in the centre of a room.
- W2075 x D600 x H450



ELEMENTS® KARST

- Elements Karst provides comfortable, durable seating in reception, libraries and staff rooms. Includes Pebble Table.
- W2075 x D1200 x SH450

PRODUCT	CODE	SIZE (mm)
Elements Trapezoid Lounge	2 x ELETRAP03L	W2075 x D600 x SH450
Pebble	1 x PEBB400	W400/350 x D400 x H650



ELEMENTS® FOREST

- The Elements Forest setting combines informal seating, 2x convenient triangle tables and the greenery of Planta.
- W3425 x D1500 x SH450
- Plants not included

PRODUCT	CODE	SIZE (mm)
Elements Trapezoid Lounge	4 x ELETRAP02L	W2075 x D600 x SH450
Elements Triangle Table	2 x ELETRIOT	W650 x D562 x H450
Planta 1370	2 x ELETRAP02L	W1370 x D300 x H800



ELEMENTS® HEXAGON OTTOMAN
ELEHEXOT

- Breakout spaces in need of comfort seating? The Elements Hexagon Ottoman is just the piece you've been looking for.
- W1380 x D1200 x H450

ELEMENTS® TOR



- This informal and comfortable Elements Tor setting includes 3x Hexagonal ottomans and 2x Pebble Tables.
- W3464 x D1800 x H450

PRODUCT	CODE	SIZE (mm)
Elements Hexagon Ottoman	3 x ELEHEXOT	W1380 x D1200 x H450
Pebble	1 x PEBB400	W400/350 x D400 x H650



ELEMENTS® TRIANGLE TABLE
ELETRIOT

- The Elements Modular Lounge system includes an angular occasional table giving you the convenience of a table top.
- Strong plywood construction
- W650 x D562 x H450

Elements Air Modular Lounge



ELEMENTS® TRIANGLE
ELEATRIOT

- Short on space? Then the Elements Triangle is for you! With its light footprint, it provides contemporary casual seating.
- W680 x D590 x H450



ELEMENTS® DIAMOND
ELEADIAOT

- Elements Diamond is an angular shaped ottoman ideal for modern spaces to create drama and excitement.
- W1100 x D600 x H450



ELEMENTS® TRAPEZOID 2 SEAT
ELEATRAPO2B

- Angular, yet comfortable, the Elements Trapezoid is light and modern and right at home in any breakout space.
- W1370 x D600 x H450



ELEMENTS® HEXAGON
ELEAHEXOT

- Elements Hex Ottoman is a cute addition to any space. Angular yet comfortable, its a great place to perch.
- W1380 x D1200 x H450



ELEMENTS® TRAPEZOID 3 SEAT
ELEATRAPO3B

- Ideal against a wall or doubled up as the centrepiece of a room, the Elements Large Trapezium is generously sized.
- W2075 x D600 x H450



Combine and reconfigure to update your space

ELEMENTS® NIMBUS

- Elements Nimbus is a modern and stylish 3 piece setting that can be used together or separated out.
- W1378 x D1200 x H450
- 1 x ELEATRAPO2B W1370 x D600 x H450
- 1 x ELEADIAOT W1100 x D600 x H450
- 1 x ELEATRIOT W680 x D590 x H450



ELEMENTS CUMULUS

- The Elements Cumulus setting provides an expansive breakout seating solution that can be joined and separated.
- W2400 x D1684 x H450
- 2 x ELEAHEXOT W1370 x D600 x H450
- 1 x ELEADIAOT W1100 x D600 x H450



NOVA + PEBBLE

- These modular little lounges are easy to reconfigure to suit groups of any size. Pebble tables provide a handy surface.
- 4 x NOVA01 W580 x D680 x SH400
- 2 x PEB001 W400 x D400 x H650



NOVA SINGLE SEAT LOUNGE
NOVA01

- With clean lines and voluptuous cushioning, this comfy lounge is a popular choice.
- W580 x D680 x SH400



NOVA TWO SEAT LOUNGE
NOVA02

- The cosy Nova Lounge with its clean lines and voluptuous cushioning is very versatile.
- W1200 x D680 x SH400
- Table not included



ARCADIA 2 SEAT LOUNGE
ARCA02L

- Arcadia combines durability and style. With plush foam seats for a cosy experience.
- W1960 x D660 x SH440



SINGLE SEAT LOUNGE
ARCA01L

- Arcadia combines durability and style. With plush foam seats for a cosy experience.
- W930 x D660 x SH440



ARCADIA OTTOMAN
ARCA01B

- Arcadia combines durability and style. With a plush foam seat for a cosy experience.
- W670 x D550 x H440

Steamroller Mobile Maker Range

STEM | STEAM | MAKER SPACES



STEAMROLLER MAKER ACCESS

- The Steamroller Maker Table is available in two heights and is ideal for coding, robotics or any activity that needs room to explore.
- Stools not included
- SRTA1812 W1800 x D1200 x H720
- SRBE1812 W1800 x D1200 x H900



STEAMROLLER MAKER ENGAGE

SRBE1812T15

- The Steamroller Maker Engage Table allows students to get up close whilst keeping resources and supplies conveniently at hand.
- Holds 15 totes (sold separately, see pg. 69)
- W1800 x D1200 x H900



STEAMROLLER MAKER EXPLORER

SRBEEEXP1812

- The Steamroller Maker Explorer Table with its 20 pull out totes can accommodate resources for the entire class as they explore.
- Totes sold separately (see pg. 69)
- W1800 x D1200 x H900

STEAMROLLER MAKER ACTION

SRBEACT1812

- The Steamroller Maker Action Table offers generous storage for resources right in the centre of the action, ready to explore!
- Holds 30 totes (sold separately, see pg. 69)
- Stools not included
- W1800 x D1200 x H900



STEAMROLLER MAKER ASSEMBLE

SRBEASSE1812

- The Steamroller Maker Assemble Table with its numerous storage drawers will have you exploring, learning and interacting.
- Drawers included
- W1800 x D1200 x H900

STEAMROLLER MAKER PLANNER

SRBEPLAN1812

- The Steamroller Maker Planner Table provides generous cupboard storage right at the table for robotics and other resources.
- Cupboard & Doors included
- Stools not included
- W1800 x D1200 x H900

Classroom Rugs

MOSAIC SKY RUG

Overall size: 1.78m x 2.34m rectangle
 – 4.9m² sitting area.
 TCRUGMSKY



4.9m²

I LOVE MY ABC'S RUG

• Overall size:
 • 4m x 3.3m rectangle - 13.2m² sitting area.
 TCRUGLABC



13.2m²

TEN FRAMES CARPET WITH DISCS

• Overall Size: 3m x 2m - 6m² sitting area.
 • Includes 20 blue and green discs (10 of each colour)
 • Disc size: 33cm in diameter
 TCRUGTFID

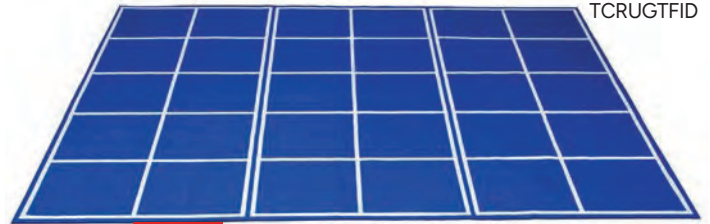

6m²

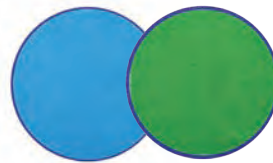

RAINBOW CARPET DISCS

• 10 per pack, 33cm diameter.
 TCRUGRBD



6m²

RAINBOW BLOCKS RUG

• Overall size:
 • 3m x 2m for 6m² seating area!
 TCRUGRB

SOLID COLOUR RUGS

• Overall size:
 • 3m x 4m for 12m² seating area!
 Blue TCRUGSB
 Green TCRUGSG

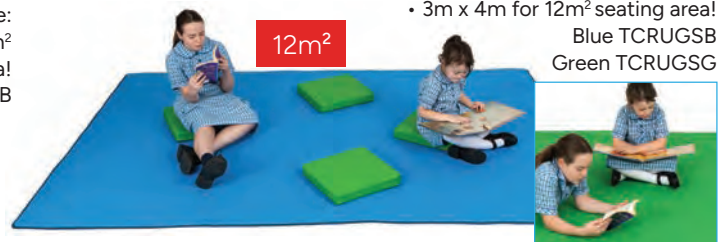

12m²

COLOUR SQUARES PLACEMENT RUG

• Overall size:
 • 3m x 2m rectangle - 6m² sitting area.
 TCRUGCSP



6m²

COLOUR SQUARES PLACEMENT RUG - LIGHT BLUE BACKGROUND 30 SQUARES

• Overall size:
 • 3m x 4m for 12m² seating area!
 TCRUGCSLB30



12m²

INDIGENOUS SEASONS RUG

• 2 sizes available:
 Large - 3m x 2m
 (6m² sitting area)
 TCASCL
 Small - 1.5m x 1m
 (1.5m² sitting area)
 TCASCS



6m²

1.5m²

CAMPFIRE RUG

• 3m x 4m - 12m² sitting area
 TCRUGCAMP



12m²

Benches & Tables

Citi & AXIOM BENCHES

Range of sizes

- Lengths: (CT) 1200, 1500, 1800mm (AX) 2400, 3000, 3600mm
- Depths: (CT) 600, 750, 900 (AX) 1200mm
- Heights: 1050mm or 900mm
- Double frames available for long benches (AXBL)
- Many options available

Tops



Frames



Citi 50/50 Bench	Static (Adj Feet)	Mobile (Lockable Castors)
TOP SIZE	CODE	CODE
1200 X 600	CT5BE1260	CT5BEM1260
1500 X 750	CT5BE1575	CT5BEM1575
1800 X 750	CT5BE1875	CT5BEM1875
1800 X 900	CT5BE1890	CT5BEM1890

x = H (1050mm high) or L (900mm high)



MOBILE BENCH



TRESTLE HIGH BENCH

Code	Top Size
TRBL1890	1800 x 900
TRBL2190	2100 x 900
TRBL3690	3600 x 900
TRBL4290	4200 x 900

Trestle Bench

- 1050m High
- White or Black 50x50mm frame
- 50x25mm rails
- Central foot rail 350mm above floor



TIMMY STEEL-FRAME TABLES & BENCHES

Choose the size that suits your needs! Best prices!

4 LEG TABLES



FOLDING TABLES



Black frame only

Frames



ALSO AVAILABLE
"Tested and Certified" model
Emmy Steel frame table
EMSFXXXX \$POA

BENCHES

QUICK SHIP COLOURS

- Priced in Select Beech, Red Cherry, Natural Oak or White Tops
- Many sizes & colours available \$POA
- 40mm sturdy steel tube with 25mm Top
- Adjustable feet



SIZES	A 4 LEG (BLACK) (735mm H)	B BENCHES (1025mm H)	C FOLDING (SILVER) (735mm H)
900 X 600	TISF0960	TISFH0960	-
1200 X 600	TISF1260	TISFH1260	-
1500 X 750	TISF1575	TISFH1575	SHFT1575
1800 X 750	TISF1875	TISFH1875	SHFT1875
1800 X 900	TISF1890	-	SHFT1890

TIMMY TABLES - 19 COLOURS & MANY SIZES AVAILABLE \$POA

1.600 X 600	6.1200 X 600	11.1500 X 750	16.1800 X 900
2.600 X 750	7.1200 X 750	12.1500 X 900	17.1800 X 1200
3.900 X 600	8.1200 X 900	13.1500 X 1200	18.2100 X 600
4.900 X 750	9.1200 X 1200	14.1800 X 600	19.2100 X 750
5.900 X 900	10.1500 X 600	15.1800 X 750	20.2100 X 900
LENGTHS: 600/900/1200/1500/1800/2100mm		21.2100 X 1200	
WIDTHS: 600/750/900/1200mm		HEIGHTS: 735/1025mm	

Satellite Teacher's Caddy

**SATELLITE TEACHERS
CADDY**
SATCADDY



- Base size: W485 x D500 x H1070
- With slide out worktray
- Heavy duty locking castors
- Gang lock (all locking drawers)

**SATELLITE TEACHERS
PODIUM**
SATPODIUM



- Base size: W485 x D500 x H1070
- Top size: W750 x D600
- With slide out worktray
- Heavy duty locking castors
- Gang lock (all locking drawers)

**SATELLITE TEACHERS
CADDY WITH SHAPED TOP**
SATCADDYT



- Base size: W485 x D500 x H1070
- Top size: W900 x D550
- With slide out worktray
- Heavy duty locking castors
- Gang lock (all locking drawers)

Erasable surface (optional)

**SATELLITE TEACHERS
LECTERN**
SATLECTERN



- Base size: W485 x D500 x H1070
- With slide out worktray
- Heavy duty locking castors
- Gang lock (all locking drawers)

Many other colours available (see pg. 90)



STERLING

A OPEN SHELF



Open
SATE020.LT



Open with top
SATE020.TLT

B 2 DRAWER + CUPBOARD



With routed handles
SATE03S.LT

With slimline handles
SATE03H.LT



With top & routed handles
SATE03TS.LT

With top & slimline handles
SATE03TH.LT

C 2 DRAWER + 2 FILE



With routed handles
SATE04S.LT

With slimline handles
SATE04H.LT



With top & routed handles
SATE04TS.LT

With top & slimline handles
SATE04TH.SV



Teaching Aids

DYNAMIC FLIP TABLE

DYTFLLIPOP



- Height Adjustable
- Height ranges: 675/715/745mm
- Mobile
- Top size: W600 x D500mm (Silver)

.sv



PEBBLE SIDE TABLE

PEBB400



- 400/350W x 400D x 650H
- Solid steel design with heavy base for stability
- Available in Black or White



FUSION MOBILE LEARNING CENTRE

FUSLEARN

- Heavy duty locking castors
- Includes magnetic whiteboard
- Includes rear storage
- Strong paper holder
- H1560 x W830 x D450mm
- *Tote boxes extra TOTE120

NEW-MATIC GAS LIFT BREAKROOM TABLE

NMMT800



- Unique patented pneumatic air lift mechanism
- Table top 800mm in 18mm white E1 melamine
- Height adjustable 688-1058mm
- 40mm lockable castors with powder coated ivory steel stand

TOWER



TEACHTOW18

TEACHTOW12

- Double sided (side 1 as pictured, side 2 one shelf)
- TEACHTOW12 1000D x 600W x 1200H
- TEACHTOW18 1000D x 600W x 1800H
- Mobile whiteboard and storage unit
- Totes sold separately (see page 69)

HUBBLE MOBILE WHITEBOARD

TRHUB1808



- 1800H x 840W x 374D
- Magnetic boards
- 4 x Large, easy glide castors, 2 are lockable
- Easy to pull handle on either end
- 1 x fixed shelf, 2 x adjustable on each end

POSTER HOLDER



- Holds 50 poster sleeves (sold separately - TCPS)
- Maximum print size: 102cm x 75cm
- Frame dimensions: 112cm (W) x 70cm (D) x 65cm (H) TCPH

CEO LECTERN

CEOL01



- Extra Shelf
- LED Lamp (Batteries Inc)
- Locking Castors

"XO" MOBILE RESOURCE CENTRE

XORESC01



- Steel handle
- H1000 x W598 x D450mm
- Lockable single drawer and door

ATOM HEIGHT ADJUSTABLE TROLLEYS

ATOM02.BK



ATOM03.BCH



GLA Dividers

BLOK SCREENS



- 1500H x 1500W BLOK1515
- 1500H x 1800W BLOK1518
- 1800H x 1500W BLOK1815
- 1800H x 1800W BLOK1818
- 50mm thick
- Pinnable surface



CITI FREE STANDING PANEL SCREEN



1200H

- 750W CTFS1275
- 1200W CTFS1212
- 1500W CTFS1215
- 1800W CTFS1218

1500H

- 750W CTFS1575
- 1200W CTFS1512
- 1500W CTFS1515
- 1800W CTFS1518

E-Z MOBILE DIVIDING SCREEN - HALF GLASS

EZMLSxxG



Examiner Trolley Range

- Wave or Straight Top
- Pinable/Velco Surface
- Solid panel - half glazed window
- Mobile Castors
- Many sizes and screen colours available

E-Z MOBILE DIVIDING SCREEN

EZMLSxx



- Wave or Straight Top
- Pinable/Velco Surface
- Solid Panel
- Mobile Castors
- Many sizes and screen colours available

GREAT DIVIDER



A Great Dividers are a brand new rolling wall system for flexibly dividing space and providing effective visual and acoustic barriers. While providing excellent space division, when not being used they simply fold up and roll away in seconds into a compact and storable unit. Great Dividers are a completely modular system allowing you to add panels to create the length of divide you need, up to 7.5 metres long. For even longer configurations units can be ganged together.

- Dividers come in two heights: 1820mm high (6 foot) or 2438mm high (8 foot)
- Wall panels available in Blue fabric or a pair of dry-erase whiteboard
- Fabric panels are pinnable with a soft substrate, which also aids sound attenuation

A Great Divider Starter Set - complete and ready to use or ready to be added to with add-on panels



A

GREAT DIVIDER STARTER 1800
GRDSTART18.BL

GREAT DIVIDER STARTER 2400
GRDSTART24.BL



B

GREAT DIVIDER ADD-ON 1800
GRDADDON18.BL

GREAT DIVIDER ADD-ON 2400
GRDADDON24.BL



C

GREAT DIVIDER ADD-ON WHITEBOARD 1800
GRDADDON18.WB

GREAT DIVIDER ADD-ON WHITEBOARD 2400
GRDADDON24.WB

- 3 wall panels (2 x 850mm & 1 x 820mm wide)
- 2 perpendicular end panels (700mm wide)
- End panels include locking casters for added stability

B Great Divider Add-on Panel

- Come in hinged pairs with each panel measuring 820mm wide
- 2 heights: 1820mm high (6 foot) or 2438mm high (8 foot)

- Optional dry-erase whiteboard features a high pressure laminate dryerase surface that provides smooth writability, easy erasability and exceptional durability
- Up to 3 pairs of Add-on panels can be joined to each Starter Set to create large-format flexible walls, up to 7.5m long
- Longer configurations units can be ganged together - please enquire

Examiner Trolley Range



PUZZLE & BOOK MOBILE BOOKCASE

EXBCMOB

- 1200W x 450D x 1000H



MOBILE ART DRYING TROLLEY

EXTRDRY

- Heavy duty lockable castors
- 14 drying shelves
- Powdercoated steel frame
- H1200 x W800 x D600mm

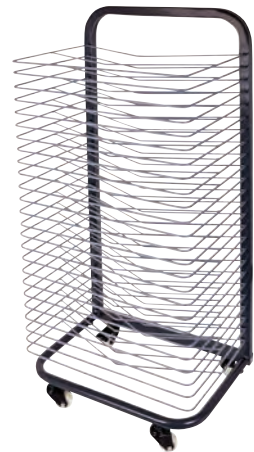

ART DRYING PACK

ARTDR25

- 25 shelves
- 2 x lockable castors
- 2 x standard castors



TV/VIDEO

EXTRTV

- Black frame
- H1220 x W850 x D600mm
- 18mm E-Zero melamine shelves
- Heavy duty castors



MOBILE ART

EXTRART

- Powdercoated steel frame
- H975 x W720 x D485mm
- 4 shelves • Includes 6 totes
- Heavy duty lockable castors



GENERAL PURPOSE

EXTR3T

- Three powdercoated shelves
- H840 x W590 x D540mm
- Heavy duty lockable castors with corner buffers



BOOK TROLLEY

EXTRLIB

- Locally manufactured
- H950 x W810 x D475mm
- Available in a range of colours
- 3 tiers • 2 double-sided shelves
- Heavy duty castors



LABORATORY

EXTRLAB

- Two powdercoated shelves
- H820 x W810 x D470mm
- Heavy duty lockable castors with corner buffers



MOBILE TRAY STORAGE

EXTRTOTE12

- Powdercoated tubular steel frame
- H870 x W820 x D575mm
- Heavy duty castors
- Holds 12 SF120 trays (not included)
- Tote size H90 x W530 x D450mm

Storewell Storage

Customise your Storewell Storage with optional totes, drawers & doors

MANY Colours available POA

See pg. 90

STOREWELL 8 BAY
STSTOREH08



- The ultimate in storage, the Storewell 8 Bay unit can hold it all with its configurable doors, drawers and tote boxes.

STOREWELL 8 BAY + TOTES



STOREWELL 8 BAY + MIXED TOTES



STOREWELL 8 BAY + DRAWERS



STOREWELL 8 BAY + DOORS



STOREWELL 6 BAY
STSTOREH06



- The Storewell open bay unit can easily be customised to meet all your storage needs with the range of accessories.
- W1200 x D450 x H854

STOREWELL 6 BAY + DRAWERS + TOTES



- Storewell pairs with removable tubs making them ideal for project work, and doors to hide away other equipment.

STOREWELL 4 BAY
STSTOREH04



- The ever practical Storewell 4 bay is a flexible solution for your storage needs. Ideal for offices and classrooms.
- W870x D450 x H854

STOREWELL 4 BAY + DRAWERS



- Ideal for STEM spaces, classrooms, staff offices, admin, libraries and anywhere else resources need to be homed.

Also available in vertical format

STSTOREV08



STSTOREV06



ACCESSORIES

*See tote colours bottom of pg. 69



TOTES			DOORS		DRAWERS	
DESCRIPTION	LENGTH mm	CODE	DESCRIPTION	LENGTH mm	DESCRIPTION	LENGTH mm
Mini Tote	365W x 420D x 115H	TOTE120	Single Door	375W x 18D x 375H	Small Drawers	375W x 420D x 187H
Maxi Tote	365W x 420D x 270H	TOTE220	-	-	Large Drawers	375W x 420D x 375H

Cubo Seat & Storage



Customise your Cubo Storage with optional totes, drawers & doors



CUBO SINGLE SEAT
CUBOSEAT01

- The compact, mobile Cubo Single is a cute little ottoman with underneath storage.
- W414 x D450 x H511



CUBO 2 SEAT
CUBOSEAT02

- Cubo Double features a soft cushion top ideal for casual seating with underneath storage.
- W807 x D450 x H511



CUBO 3 SEAT
CUBOSEAT03

- Cubo Triple provides a long, mobile padded bench with generous underneath storage for resources or bags.
- W1200 x D450 x H511



CUBO 4 SEAT
CUBOSEAT04

- The long Cubo Quad provides lots of seating and storage all in the one mobile unit. Use back to back in open spaces.
- W1593 x D450 x H511

Double Sided



CUBO 8 SEAT
CUBOSEAT08

- Cubo Octad is ideal for the centre of a room, being accessible both sides. Soft cushion top, generous storage.
- W1593 x D900 x H511

VE E0 Melamine Colours

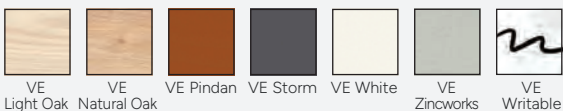
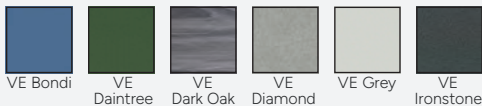

VE Fabric Colours



Book Storage

MANY Colours available POA

See pg. 90



FUSION WEMBLEY
FUSSTOREWEMB

- Fusion Wembley sits atop a storage frame to create a browser and organisation centre.
- W1200 x D900 x H1172
- Totes sold separately (see page 69)

FUSION BOOKCASE
FUSSTOREBC12

- The Fusion Mobile Bookcase is accessible both sides for book display. Includes lockable castors.
- W900 x D450 x H1230

FUSION BROWSER
FUSBOOKBR

- The Fusion Book Browser sits atop a lightweight frame and is ideal for book browsing in school libraries.
- W1200 x D900 x H750



KUBE MAXI
KUBEMAX

KUBE MIDI
KUBEMID

RUBIX MAXI
RUBIXMAX

RUBIX MIDI
RUBIXMID

RUBIX TOWER
RUBIXTOW

BOOK SPINNER
BOOKDISSPIN

- The Kube Maxi Browser is ideal for highlighting popular book collections or series in an easy to select book display unit.
- Two sided storage
- **Kube Maxi** W804 x D804 x H1074
- **Kube Midi** W804 x D804 x H681

- The Rubix Maxi Browser is ideal for fiction series books with accessibility all sides for easy access and selection.
- Four sided storage
- **Rubix Maxi** W1200 x D1200 x H1311
- **Rubix Midi** W1200 x D1200 x H1088

- The Rubix Book Tower is ideal for highlighting popular book series for quick access all sides making book selection easy.
- Four sided storage
- W804 x D804 x H1690

- This spinner features 5 tiers, is free standing and rotates. Holds approximately 180 paperbacks or 250 series books.
- W580 x D580 x H1610

BAG STORAGE

MANY Colours available POA

See pg. 90



Taller height fits standard sized school bags + tote



STOREWELL 4 BAG STORAGE UNIT
STSTOREBAG04

- Accommodating a school bag and tote for each student, the Storewell Bag + Tote unit is a classroom staple.
- W810 x D500 x H1075
- Totes sold separately (see page 69)

STOREWELL 8 BAG STORAGE UNIT
STSTOREBAG08

- This classroom staple accommodates a school bag and tote for each student to keep student belongings together.
- W1600 x D500 x H1075
- Totes sold separately (see page 69)

Tote Trolleys

Now you can customise your tote tray trolleys

TC Single Tote Trolley

TCXTOTTR1

- Fits 5 standard totes
- 38cmW x 44cmD x 92cmH
- Tote Trays sold separately (refer plastic totes below)



TC Double Tote Trolley

TCXTOTTR2

- Fits 10 standard totes
- Overall size: 74cmW x 44cmD x 92cmH
- Tote Trays sold separately (refer plastic totes below)



TC Triple Tote Trolley

TCXTOTTR3

- Fits 15 standard totes
- Overall size: 110cmW x 44cmD x 92cmH
- Tote Trays sold separately (refer plastic totes below)



Plastic Tote Trays

TCXTOTTRAY



Trolley Top colours

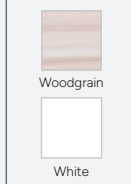

Letter Storage Tray Insert on its own
TCXINS28



Tote Lid (sold separately)
TCXTRAYLID



Storewell 5 Tote

STSTORETOTE05

- Overall size: 414cm(W) x 450cm(D) x 904cm(H)
- Removable totes sold separately (refer Storewell Totes below)



MANY Colours available POA See pg. 90

Storewell 10 Tote

STSTORETOTE10

- Overall size: 807cm(W) x 450cm(D) x 904cm(H)
- Removable totes sold separately (refer Storewell Totes below)



Storewell 15 Tote

STSTORETOTE15

- Overall size: 1200cm(W) x 450cm(D) x 904cm(H)
- Removable totes sold separately (refer Storewell Totes below)



Storewell Tote Trays

White

TOTE120.WH

Charcoal

TOTE120.CH

Orange

TOTE120.OR

Light Green

TOTE120.GNLT

Cranberry

TOTE120.BUR

Purple

TOTE120.PU

Classic Totes

420W x 365D x 120H



Maxi Totes

420W x 365D x 220H



TOTE220.WH

TOTE220.CH (Stocked)

TOTE220.OR

TOTE220.GNLT

TOTE220.CRA

TOTE220.PU



Tub shelves ideal for picture books

OPTIMA 1200 SINGLE SIDED

- Ideal for primary schools with its low height accessibility, this single sided unit is ideal under windows or against walls.
- W950 x D375 x H1175



OPTIMA 1200 DOUBLE SIDED

- Ideal for primary schools with its low height accessibility, this double sided unit is ideal in libraries and resource centres.
- W950 x D650 x H1175



OPTIMA 1500 SINGLE SIDED

- Ideal for primary or secondary schools with its mid height accessibility, this single sided unit suits use against a wall.
- W950 x D375 x H1575



Flat shelves available 250 or 300mm D



OPTIMA 1500 DOUBLE SIDED

- Ideal for primary or secondary schools this double sided unit is ideal in libraries and resource centres.
- W950 x D650 x H1575



Angled shelves for face out display

OPTIMA 1800 SINGLE SIDED

- Ideal for larger collections, this maxi height unit holds a range of resources. Use against a wall.
- W950 x D375 x H1775



OPTIMA 1800 DOUBLE SIDED

- Ideal for larger collections in secondary or tertiary this double sided unit is ideal in libraries.
- W950 x D650 x H1775

Storewell Locker - MDF/Steel frame

FULL HEIGHT OPTIONS - ALSO AVAILABLE 1270MM H, 970MM H

Single-bay Lockers

Dimensions

Double-bay Lockers

Dimensions

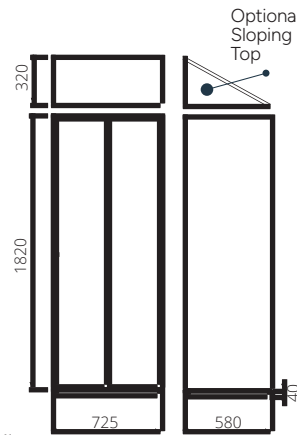
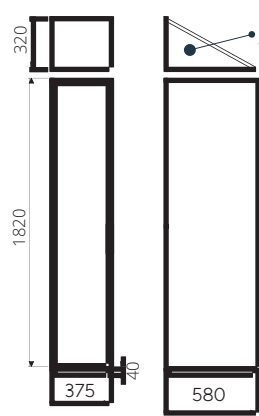

Single Door LKEDH101
Two Door LKEDH201
Three Door LKEDH301

Single Door LKEDH102
Two Door LKEDH202
Three Door LKEDH302

Triple-bay Lockers

Dimensions



Single Door LKEDH103

Two Door LKEDH203

Three Door LKEDH303

7 YEAR WARRANTY

Infinite Melamine Lockers

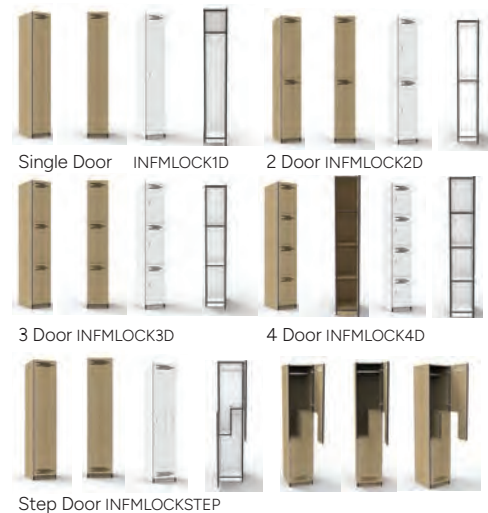

- 305W x 455D • Available in White or Natural Oak
- Includes 2 keys per lock
- Soft close hinges • MDF doors with clear sealant on vent cutouts
- Digital lock available with private or public lock programming INFLOCK.BK

Style	Code
Single Door	INFMLOCK1D
2 Door	INFMLOCK2D
3 Door	INFMLOCK3D
4 Door	INFMLOCK4D
Step Door	INFMLOCKSTEP

We do customised lockers!



You can create your own unique locker installation in three simple steps:

1

Choose Locker Body

Select from 5 different locker "footprint" sizes - A series, B series (deepest unit), C series (widest unit), D series (narrowest unit), and the E series. All are available in 1-9 hinges.



A Series



B Series



C Series



D Series



E Series

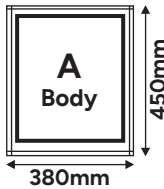

A Body

380mm

450mm

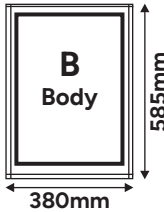

B Body

380mm

585mm

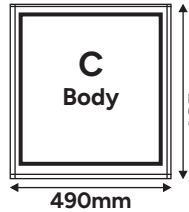

C Body

490mm

485mm

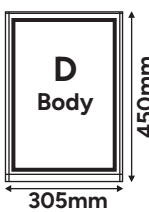

D Body

305mm

450mm

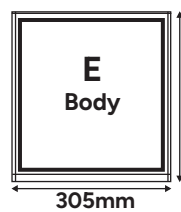

E Body

305mm

305mm

Suits the small door. Avail. 1-9 hinge

Same width as A but deeper body. Avail. 1-9 hinge

Wider body for wider door. Avail. 1-9 hinge

Narrowest body. Avail. 1-9 hinge

Same width as D but shallower body. Avail. 1-9 hinge

Choose Locker Height

Choose from 1 - 9 hinge heights. You can select how many separate lockers you want to have in a single body. Every locker body size comes in 1 to 9 hinge options.

2



All locker body footprint sizes available from a single hinge through to 9 hinges

Accessories

1 Sloping Top

2 USB Cable

3 Pad-Lockable L-Shaped handle

4 Combination Locks

5 Key Lock Coin retain or Coin return locks.

6 Garment Hook

7 Shelf with hanging rail.

8 Additional Shelves

9 Customisable Steel Number Plates

10 Kicker Base

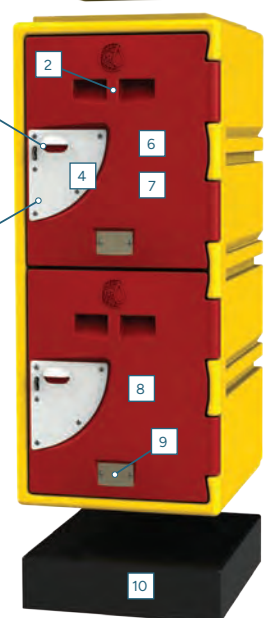

3

Choose Locker Door(s):

Choose from 1 - 9 hinge heights. You can select how many separate lockers you want to have in a single body. Every locker body size comes in 1 to 9 hinge options.

EDU Lockers & Phone Lockers

EDU Lockers (Aus. Pat No. 2011903047) have unique advantages over lockers made from traditional materials such as wood, laminate and metal, here are some:

- UV stable with a huge range of anti-fade colours to choose from
- Lightweight & stackable so they are easy to move and install
- The lockers are made of Heavy Duty Polyethylene with a high-grade stainless steel hinge - so they are perfect for wet areas, coastal locations and the outdoors
- Quieter than metal or timber lockers, no banging doors
- Graffiti is easier to remove - no painting required
- Easy to clean and lowest maintenance, just hose them out!
- Proven strength and durability - backed by a 15 year warranty
- Options: Sloping top, kick base, number plates, hanging rails/hooks & USB cable

HUGE colour range!

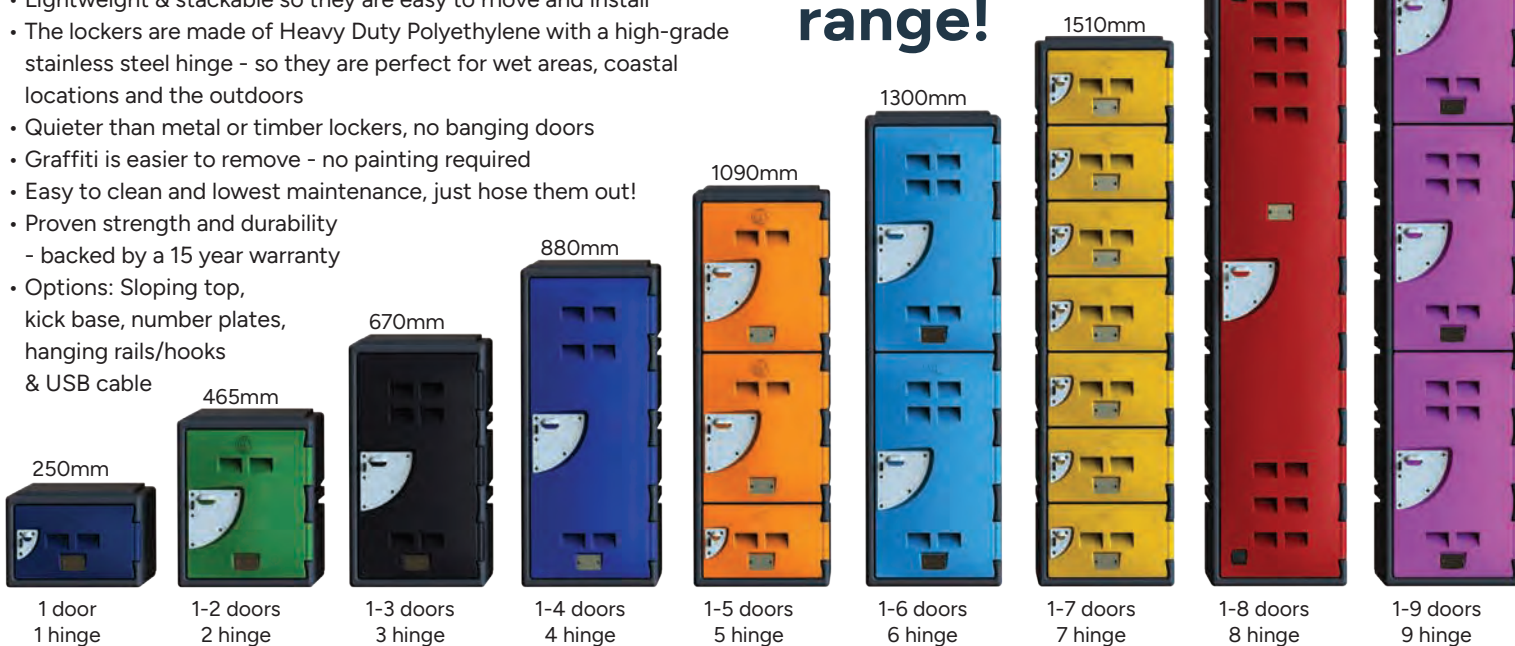

Mobile Phone Locker

FSPPHONE

Optional USB wiring kit for Phone Lockers include 4 ports and wires. FSPPHONEKIT

- 4 door vertical - 180W x 240D x 600Hmm
- UV Stable
- Lightweight and Stackable and or Mountable
- Heavy Duty Polyethylene with a high-grade stainless steel hinge
- Strong and Durable



SICO® Portable Stage Package



4 x 1800 Series 1830W
x 2440L Units, Steps,
Guardrails & Drapes

SICO® 1800 Series Stage

Each section of our mobile 1800 Series Portable Stage is designed to be handled and set up by just one person, creating significant time savings and minimal effort for you.



One Person Set Up



Compact Storage Profile

SICO 1800 Series Stage Units - Standard Black Carpet		
Stage Unit Size	Unit Height	Code
1830W x 2440L	Fixed Single Height 410H	STAG1824F4
1830W x 2440L	Fixed Single Height 610H	STAG1824F6
1830W x 2440L	Dual Height Adjustable 410H or 610H	STAG1824A46
1830W x 2440L	Dual Height Adjustable 610H or 810H	STAG1824A68

SICO 1800 Series Accessories			
Model	Step Height	Suits Stage Height	Code
1 Step Unit	410H	410H	STAGSTEP01
2 Step Unit	410H or 610H	41cm & 61cm	STAGSTEP02
3 Step Unit	610H or 810H	61cm & 81cm	STAGSTEP03
Back Guardrail	1830L x 1060H	1800 Series	STAGGR18
Back Guardrail	2440L x 1060H	1800 Series	STAGGR24
Single Height Stage Drapes	410H, or 610H or 810H	2440H or 4270L	STAGDRAPF
Dual Height Stage Drapes	410H-610H or 610H to 810H	2440H or 4270L	STAGDRAPA

The Original All In One

Preferred by Australian schools for over **3 decades** for its all in one design and ease of use. The SICO 1800 Series Stage is the original all in one unit.

SAVE TIME

Time saving, all in one unit - No loose parts to assemble. One person operation - Easily rolls from storage areas out into use.

VERSATILITY

One stage, multiple configurations. From speaker platforms to a tiered riser set ups, the adjustable height option provides build in versatility.

WIDE RANGE OF ACCESSORIES

Customise your set up preferences including steps, guardrails, drapes and wheel chair accessible ramps.

SICO® Harmony Choral Risers



Preferred By Aussie Schools for 30 Years!

Reverse Steps without Tools

These innovative risers have a quick reverse-step system that makes it easy to change your riser configuration from the traditional semi-circular arrangement to straight or other interesting combinations without tools!

Use this feature to build unique configurations show-choir, or double-choir concerts.



SICO Harmony Choral Riser - Standard Grey Carpet		
Riser Size	Unit Height	Code
3 Step Riser	1840W x 1410D	CHOR03
4 Step Riser	1980W x 1840D	CHOR04
Side Guardrail Set (2)	Made to Fit	CHORGR01

Roll in the Risers

SICO® Harmony Choral Risers offer quick configuration changes and are easy to transport.

- Each self-contained 3 or 4 step unit rolls into place, lower the steps with one fluid motion to the floor, lock it to the next unit, and you are ready to sing.
- Contact feet prevent sliding of risers as performers move around.
- Rear security guardrails come standard and are permanently attached to the back row of each riser.
- Transport and storage is easy for staff with no loose parts to disassemble.



Side Guardrails



One Person Set Up



Whisper Quiet Design



Folds for storage

Manual Arts & Sick Bay



OXY WELDING BENCH
EXBNWELD

- Operating area 1065 x 465mm
- H900 x W1200 x D535mm



TAFE WORK BENCH
EXBNTAFE

- Hardwood top with iron angle frame
- H825 x W1660 x D850mm



DELUXE TAFE WORK BENCH
EXBNTAFEC

- Two vices and lockable storage cupboards
- H825 x W1660 x D850mm



ARC WELDING BENCH
EXBNARCWELD

- Heavy duty steel frame
- H900 x W1200 x D600mm



WOODWORK BENCH
EXBNWW1200

- Four 175mm woodwork vices
- H810 x W1240 x D1240mm



WOODWORK BENCH
EXBNWW2400

- Two 175mm woodwork vices
- H850 x W2400 x D750mm



SICKBAY COUCH (HIGH)
BED01

- Fully welded 38mm round Black steel frame
- Ply base and back with Dunlop Enduro Foam
 - Adjustable back rest
- 1800W x 600D x 840Hmm



SICKBAY COUCH (LOW)
BED02

- Fully welded 38mm round Black steel frame
- Ply base and back with Dunlop Enduro Foam
 - Adjustable back rest
 - Includes Arms
- 1800W x 600D x 440Hmm

Aluminium Outdoor Furniture

CAROL OUTDOOR SETTING

- Seat Height: 410 mm
- All aluminium construction
- Low maintenance
- Lightweight
- Durable

Size	Code
2000W x 1770D x 710H	CAROL2000
2400W x 1770D x 710H	CAROL2400
3000W x 1770D x 710H	CAROL3000
4000W x 1770D x 710H	CAROL4000



EXAMINER OUTDOOR SETTING

EXSETTING

- Galvanised steel frame with Duragal seat & top
- Zinc Anneal
- Tamper proof stainless steel fixings
- 1800W x 1560D x 730Hmm - seat height: 460mm



CHARLIE OUTDOOR BENCH SEAT

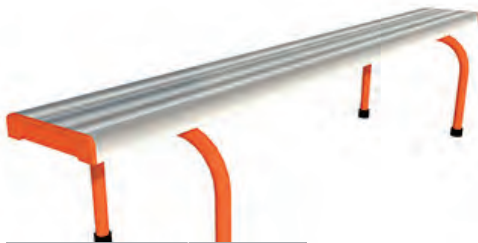

Size	Code
2000W x 255D x 450H	CHAR2000
2400W x 255D x 450H	CHAR2400
3000W x 255D x 450H	CHAR3000
4000W x 255D x 450H	CHAR4000

- All aluminium construction
- Low maintenance
- Lightweight
- Durable
- Rubber feet
- Stackable



HARVEY BOLT-DOWN BENCH SEAT



- All aluminium construction
- Low maintenance
- Lightweight
- Durable

Size	Code
2000W x 255D x 400H	HARV2000
2400W x 255D x 400H	HARV2400
3000W x 255D x 400H	HARV3000
4000W x 255D x 400H	HARV4000



MORRIE BOLT-DOWN BENCH SEAT



- All aluminium construction
- Low maintenance
- Lightweight
- Durable

Size	Code
2000W x 255D x 700H	MORR2000
2400W x 255D x 700H	MORR2400



POWDERCOAT FRAME & END CAPS AVAILABLE IN A SELECTION OF DULUX COLOURS. \$POA

CAMERON FREESTANDING BENCH SEAT



- All aluminium construction
- Low maintenance
- Lightweight
- Durable
- Rubber feet
- Coloured Supports and End Caps

Size	Code
2000W x 255D x 700H	CAME1800
2400W x 255D x 700H	CAME2000
3000W x 255D x 700H	CAME2400
4000W x 255D x 700H	CAME3000



MADDIE WALL MOUNTED BENCH SEAT



- All aluminium construction
- Low maintenance
- Lightweight
- Durable

Size	Code
2000W x 255D x 50H	MADD2000
2400W x 255D x 50H	MADD2400
3000W x 255D x 50H	MADD3000



ALUMINIUM BAG RACK

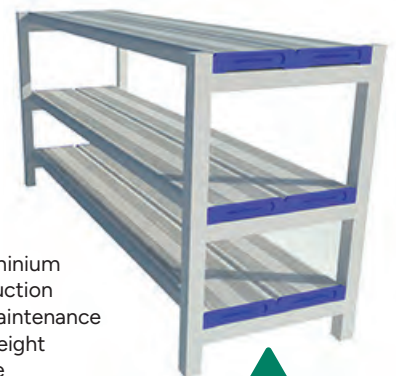

- All aluminium construction
- Low maintenance
- Lightweight
- Durable



Size	2 Tier	3 Tier
2000W x 255D x 800H	ALUM2002	ALUM2003
3000W x 255D x 950H	ALUM3002	ALUM3003

Sterling Classroom Furniture

We manufacture to your design

The Sterling range is a comprehensive selection of heavy duty furniture designed specifically for the rigours of the classroom. Many matching items available.



B



C



D



H



I



L



J



R Book Display
STBDISP/C

- 1225H x 1225W x 650Dmm
- Optional castors

Features

- Australian Made • E-Zero • Many other laminate colours available.



See all Page 92

- All adjustable shelves are 25mm - extra thick and strong

900 mm Wide Bookcases (no doors)*

Description	Code	Dimensions (mm)
Single side	A STBC0930/C	H900 x D315
	B STBC0945/C	H900 x D450
	C STBC0960/C	H900 x D600
	D STBC1245	H1200 x D450
	E STBC1260	H1200 x D600
Double side	F STBC0960/C	H900 x D600
	G STBC1260/C	H1200 x D600

* Priced without castors. Optional castors /c

900 mm Swing-Door Cupboards

Description	Code	Dimensions (mm)
Static	H STSC12	H1200 x D600
Mobile	I STSC12M	H1200 x D600
Static	J STSC18	H1800 x D600
Static	K STSC21	H2100 x D600

4 Door Credenza

Description	Code	Dimensions (mm)
Mobile	L STSC1545C	H725 x W1500 x D450

Teacher's Desk

Description	Code	Dimensions (mm)
Desk (no drawers)	M STDK1575	H725 x W1500 x D750
Desk (locking drawers)	N STDK1575D	H725 x W1500 x D750
1 Dr/File Mobile Pedestal	O STMP1DF	H590 x W470 x D530
Mobile Desk Extension	P STDKEX900	H725 x W910 x D600

* All Sterling drawers are lockable

Sterling Range



Q Mobile Book Trolley STTRBOOKC
• H680 x W1225 x D650 mm

CANASTA RANGE

CANASTA BOARDROOM



NEW

CANASTA MEETING TABLE

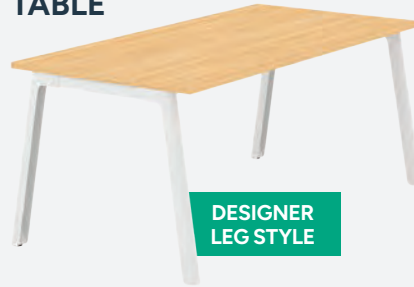

DESIGNER LEG STYLE

CANASTA ROUND TABLE



CANASTA TABLES	
CODE	SIZE
CABT2412B	2400 X 1200
CABT3012B	3000 X 1200
CAMT1890	1800 X 900

- Solid steel construction
- Adjustable feet
- Available in many other colours

CANASTA ROUND TABLES	
CODE	TOP DIA (mm)
CAMT1000	1000
CAMT1200	1200

- Solid steel construction
- Adjustable feet
- Customisable to any size between 1000mm - 1300mm (round or square)
- Available in many other colours

- Customisable to any width between 1000mm - 1600mm
- Customisable to any length between 2400mm - 7000mm
- Additional top shapes available (Rectangular, D-End, Tapered, Shark nose edging)

5 YEAR WARRANTY

MANY Colours available POA

Tops .OK .WH .RC .SB Frames .WH .BK

DISCUS RANGE

DISCUS TABLE



- Disc Base
- Indoor Use
- 720mm High

VARIETY OF TOP COLOURS AVAILABLE

TOP DIA (mm)	CODE
1000	DISCTB1000
1200	DISCTB1200

Frames

.WH .BK

Tops

.OK .SB .RC .WH

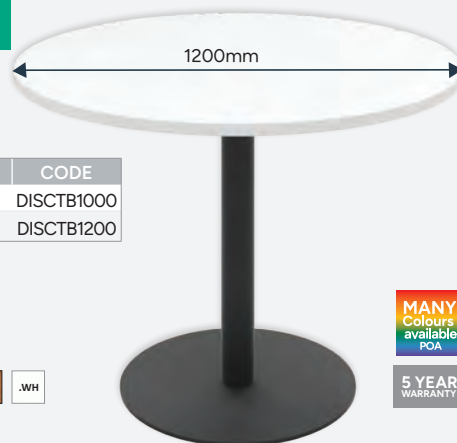

DISCUS COFFEE TABLES



- 430mm High

MANY Colours available POA

5 YEAR WARRANTY



Whiteboards

WHITEBOARD TABLET MOBILE

TRWWM1812



- 1200W x 1800Hmm
- Comes with 12 double sided whiteboard tablets
- Holds 6 tablets per size
- Features a pen tray
- Lockable Castors

ALSO AVAILABLE WHITEBOARD TABLET

TRWWM1812



- Double sided
- Rounded grey moulded plastic edges
- Carry handle and a light permanent grid on one side

THE "BIG A" PORCELAIN MOBILE WHITEBOARD

TRBIGAMW1809

- 1800H x 900W
- Large magnetic double-sided porcelain scratch resistant writing surface
- Satin silver aluminium frame finish
- Minimal assembly required
- Fold flat and store when not in use
- Large internal storage tray



BUSTLE MOBILE WHITEBOARD

TRBUSM12



- 1850H x 1110W (Board Size: 1180H x 1110W)
- Includes removable magnetic pen shelf (480W)
- Hex key included
- Dark charcoal aluminium legs
- 4x Foldable legs with gliding castors
- Powder coat orange aluminium board frame

MOBILE WHITEBOARDS



- Double-sided • Sturdy frame
- 1750mm overall height

3 YEAR WARRANTY

MAGNETIC

- H1000 x W1200mm TSMWB1210
- H1000 x W1500mm TSMWB1510
- H1000 x W1800mm TSMWB1810

WALL MOUNT WHITEBOARD

COMMERCIAL GRADE 3YR WARRANTY

- 900W x 600H TSWB0906
- 1200W x 900H TSWB1209
- 1500W x 900H TSWB1509
- 1800W x 900H TSWB1809
- 1800W x 1200H TSWB1812
- 2400W x 1200H TSWB2412
- 3000W x 1200H TSWB3012

PORCELAIN SURFACE 25YR WARRANTY

- TRRLPWW0906 Porcelain surface (vitreous enamel)
- TRRLPWW1209 whiteboards are ideal for heavy duty use such as schools, conference centres and medical facilities
- TRRLPWW1509
- TRRLPWW1809
- TRRLPWW1812
- TRRLPWW2412
- TRRLPWW3012

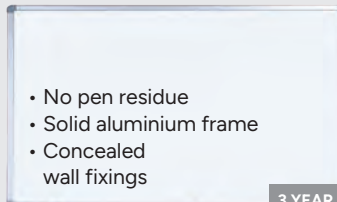

- No pen residue
- Solid aluminium frame
- Concealed wall fixings

3 YEAR WARRANTY

MAGNETIC DESIGNER GLASS BOARD



- 900W x 600H TRRLGB0906
- 1200W x 900H TRRLGB1209
- 1500W x 900H TRRLGB1509
- 1500W x 1200H TRRLGB1512
- 1800W x 900H TRRLGB1809
- 1800W x 1200H TRRLGB1812
- 2100W x 1200H TRRLGB2112
- 2400W x 1200H TRRLGB2412

Now available in black backed surface

- H600 x W1200mm TRMG1206B
- H1200 x W1800mm TRMG1812B

- Lifetime stain free surface
- 4mm safety toughened glass
- 8 times stronger than glass
- 500mm glass pen shelf
- 6 super magnets supplied



FELT PINBOARDS

- H600 x W900mm TSPB0906
- H900 x W1200mm TSPB1209
- H900 x W1500mm TSPB1509
- H900 x W1800mm TSPB1809
- H1200 x W2400mm TSPB2412

- Strong extra thick felt
- Wall fixings supplied
- Available in Blue or Grey

3 YEAR WARRANTY

COMMUNICATE ROOM DIVIDER

COMD02



- H1800 x W900mm
- Each divider can be linked together with the Connector Kit COMD01
- Side 1 – magnetic whiteboard with magnetic pen shelf and adjustable flipchart pad hooks
- Side 2 – pinnable charcoal fabric
- 90mm locking castors

3 YEAR WARRANTY

BENOTICED SLIDING DOOR NOTICE CASE

TRGNC1209S.SI/TRGNC1509S.SI



- Pinnable
- Lockable
- Aluminium Frame

BENOTICED HINGED DOOR NOTICE CASE

TRGNC1209H.SI/TRGNC1812H.SI/TRGNC1809H.SI



- Pinnable
- Lockable
- Aluminium Frame

NEW Altura Electric Workstation System

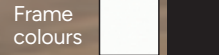

SPECIFICATIONS

- Market leading weight rating 210kg (3 motors - L shape) & 135kg (2 motors - Rectangular)
- Height range - min 635mm, max 1280mm
- Individually motorised legs (no exposed mechanism)
- Frame colour - black, white

- Anti-collision safety feature
- 4 memory pre-sets
- Smooth, silent action
- Descends at 35mm per second
- One touch activation of height mobility makes transitions quick and easy



CHOICE OF ROUND LEG OR SQUARE LEG

ALTURA STRAIGHT DESK



Melamine top colours



- Many other top colours available. \$POA

TOP SIZE (mm)	STRAIGHT DESKS HEIGHT ADJUSTABLE				FIXED HEIGHT
	DESK ONLY (NO TRAY OR SCREEN)	TRAY ONLY (NO SCREEN)	SCREEN ONLY (NO TRAY)	WITH TRAY & CITI SCREEN	BASIC (NO TRAY OR SCREEN)
	CODE*	CODE*	CODE*	CODE*	CODE*
1200W X 750D	ALxDK1275C/S	ALxDKT1275C/S	ALxDKP1275C/S	ALxDKTP1275C/S	ALxDKFX1275
1500W X 750D	ALxDK1575C/S	ALxDKT1575C/S	ALxDKP1575C/S	ALxDKTP1575C/S	ALxDKFX1575
1800W X 750D	ALxDK1875C/S	ALxDKT1875C/S	ALxDKP1875C/S	ALxDKTP1875C/S	ALxDKFX1875
1800W X 900D	ALxDK1890C	-	-	-	ALxDKFX1890
JOINING KIT (NO DIVIDING SCREEN)	ALCSSBRIDGE	ALJLSS	ALJLSS	ALJLSS	-

*1200 x 750 available in white or oak tops only

LED CONTROL PANEL (INCLUDED)



CABLE UMBILICAL



- Black or White
- 1300mm Long
- For Sit-Stand Desks

ALTURA SINGLE WORKSTATIONS



- Includes one cable entry

TOP SIZE (mm)	L - SHAPE HEIGHT ADJUSTABLE				FIXED HEIGHT
	WORKSTATION ONLY (NO TRAY OR SCREEN)	TRAY ONLY (NO SCREEN)	SCREEN ONLY (NO TRAY)	WITH TRAY & CITI SCREEN	BASIC (NO TRAY OR SCREEN)
	CODE*	CODE*	CODE*	CODE*	CODE*
1500W X 1500D	ALxWS1515	ALxWST1515	ALxWSP1515	ALxWSTP1515	ALxWSFX1515
1500W X 1800D	ALxWS1815	ALxWST1518	ALxWSP1518	ALxWSTP1518	-
1800W X 1500D	ALxWS1815	ALxWST1815	ALxWSP1815	ALxWSTP1815	ALxWSFX1815
1800W X 1800D	ALxWS1818	ALxWST1818	ALxWSP1818	ALxWSTP1818	ALxWSFX1818

*Use "R" for Round leg, use "S" for square leg



ALTURA BACK-TO-BACK



ALTURA T-POD

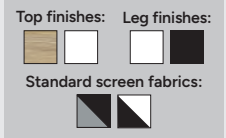
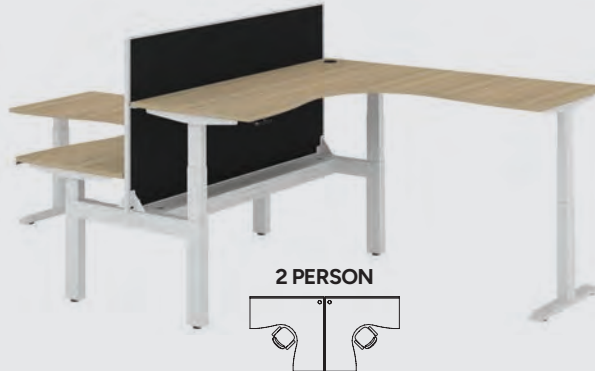

4 PERSON

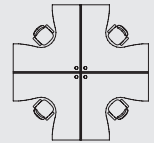

2 PERSON

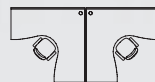

BACK TO BACK SETTING (PRICE PER PERSON)

TOP SIZE	TRAY ONLY (NO SCREEN)	SCREEN ONLY (NO TRAY)	WITH TRAY & CITI SCREEN
	CODE*	CODE*	CODE*
1200W X 750D	ALxBBT1275C/S	ALxBBP1275C/S	ALxBBTP1275C/S
1500W X 750D	ALxBBT1575C/S	ALxBBP1575C/S	ALxBBTP1575C/S
1800W X 750D	ALxBBT1875C/S	ALxBBP1875C/S	ALxBBTP1875C/S
JOINING KIT (NO DIVIDING SCREEN)	ALCBBBRIDGE	ALJLBB	ALJLBB

2 PERSON T-POD (PRICE PER PERSON)

TOP SIZE	TRAY ONLY (NO SCREEN)	SCREEN ONLY (NO TRAY)	WITH TRAY & CITI SCREEN
	CODE*	CODE*	CODE*
1500W X 1500D	ALxLTT1515	ALxLTP1515	ALxLTP1515
#1500W X 1800D	ALxLTT1518	ALxLTP1518	ALxLTP1518
^1800W X 1500D	ALxLTT1815	ALxLTP1815	ALxLTP1815
1800W X 1800D	ALxLTT1818	ALxLTP1818	ALxLTP1818





4 PERSON X-POD (PRICE PER PERSON)

TOP SIZE	TRAY ONLY (NO SCREEN)	SCREEN ONLY (NO TRAY)	WITH TRAY & CITI SCREEN
	CODE*	CODE*	CODE*
1500W X 1500D	ALxLXT1515	ALxLXP1515	ALxLXP1515
#1500W X 1800D	ALxLXT1518	ALxLXP1518	ALxLXP1518
^1800W X 1500D	ALxLXT1815	ALxLXP1815	ALxLXP1815
1800W X 1800D	ALxLXT1818	ALxLXP1818	ALxLXP1818

*Use "R" for Round leg, use "S" for square leg #Cable tray 1500 side ^Cable tray 1800 side

Admin Furniture



-  Red Cherry/Ironstone
-  Select Beech/Ironstone
-  White/Silver
-  Oak/White

10 YEAR WARRANTY



SQUARELINE

Square handle is standard on Silver/White/Oak items only. Also sold separately.



HANDLE01



HOW HEALTHY IS YOUR OFFICE?

EXCLUSIVE TO EMPIRE
Our SHIPSHAPE range uses board containing near to zero formaldehyde... Does yours?

SHIPSHAPE

- E0 Environmentally Friendly board
- 10 year commercial warranty
- Flat-packed or fully assembled
- 100s of products

4 colour combos for quick delivery

- Metal-sided drawers and runners with solid bases
- Strong cammed-construction for easy assembly
- Ball-bearing full extension runners on file drawers

- 25mm on 18mm solid melamine construction
- 2mm hard-wearing rigid PVC edge
- 2 cable entry points in all desks (excluding P-Desk)

BOOKCASE HUTCH



CODE	SIZE
SHHU12	1200W X 320D X 1075H
SHHU15	1500W X 320D X 1075H
SHHU18	1800W X 320D X 1075H

CODE	SIZE
SHDK1260	1200W X 600D
SHDK1575	1500W X 750D
SHDK1590	1500W X 900D

STRAIGHT DESK (Open)

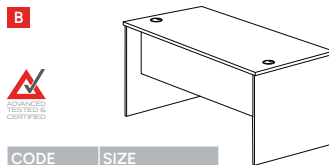

CODE	SIZE
SHDK1875	1800W X 750D
SHDK1890	1800W X 900D
SHDK2190*	2100W X 900D

RETURN (Open)



CODE	SIZE
SHRT09	900W X 600D X 727H
SHRT12	1200W X 600D X 727H

Available in left or right (Universal)

FITTED DRAWER BOX

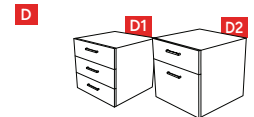

CODE	SIZE
D1 SHDB3D	3 DRAWER
D2 SHDB1DF	1 DRAWER + FILE

- Full extension ball bearing runner on file drawer
- 450H x 463W x 473D

CORNER WORKSTATION (Open)



CODE	SIZE
SHWS61221	1200W X 2100W X 600D
SHWS61521	2100W X 1500W X 600D
SHWS61821	2100W X 1800W X 600D
SHWS62121	2100W X 2100W X 600D
SHWS71818	1800W X 1800W X 750D
SHWS71821	2100W X 1800W X 750D
SHWS72121	2100W X 2100W X 750D
SHWS61212	1200W X 1200W X 600D
SHWS61215	1200W X 1500W X 600D
SHWS61218	1200W X 1800W X 600D
SHWS61515	1500W X 1500W X 600D
SHWS61518	1800W X 1500W X 600D
SHWS61818	1800W X 1800W X 600D

DELUXE HORIZONTAL BOOKCASES

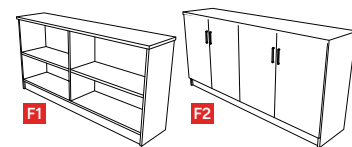

CODE	SIZE
SHBC0918	900H X 1800W X 400D
SHSC0918	WITH DOORS

DELUXE BOOKCASES

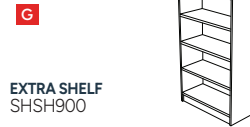

CODE	SIZE	LEVELS
SHBC09	900H X 900W X 400D	2
SHBC12	1200H X 900W X 400D	3
SHBC18	1800H X 900W X 400D	5

CREDENZA

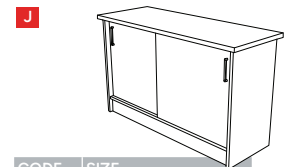

CODE	SIZE
SHCR12	1200W X 725H X 450D
SHCR15	1500W X 725H X 450D
SHCR18	1800W X 725H X 450D

MOBILE PEDESTAL

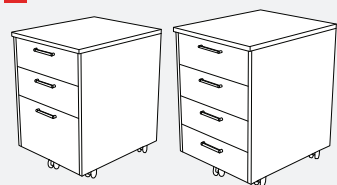

CODE	SIZE
L1 SHMP2DF	2 DRAWER + FILE
L2 SHMP4D	4 DRAWER

- 470W x 560D x 640H
- Full extension ball bearing runners
- Metal sided drawers
- Ironstone or White

STORAGE CUPBOARDS (Includes half doors)



- 25mm shelves
- 18mm back

CODE	SIZE	LEVELS
SHSC18HD	1800W X 900W X 400D	5

DESK HEIGHT CREDENZA



- Hinged doors

CODE	SIZE
SHCR09	900W X 600D X 725H

MEETING TABLE

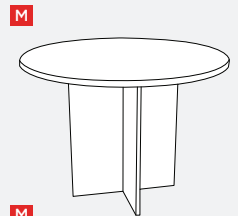

CODE	SIZE
SHMT1000	1000MM DIAMETER

Shipshape Range



WE WILL BEAT ANY WRITTEN QUOTE...EMPIRE ALWAYS GUARANTEES THE LOWEST PRICES*

BREEZE AND PLANTERS

BREEZE WITH MODESTY PANELS



STRAIGHT DESKS	
DIMENSIONS (mm)	CODE
1200 X 750*	BZDK1275
1500 X 750	BZDK1575
1800 X 750	BZDK1875

*Not available in plain tops

- Sturdy powdercoated frame and legs
- Comes with metal perforated modesty panel
- Range of sizes to choose from to suit your space
- E0 Melamine top
- 730H
- 750mm deep top for more workspace
- All tops available with cable holes, scallop tops or plain tops (Scallop tops available in Oak and White only)

LEGS



TOPS



CORNER WORKSTATIONS	
DIMENSIONS (mm)	CODE
1500 X 1500	BZWS1515
1800 X 1200	BZWS1815
1800 X 1500	BZWS1818

PLANTA

Planta 1200

Includes 3x 200mm pots and the Ezy irrigation kit for real or artificial plants.

PLLOW1200

W1200 x D300 x H450

PLHIGH1200

W1200 x D300 x H800



Planta 1370

Ideal as a divider between tables and lounges to provide privacy. 3 x 200mm pots.

PLLOW1370

W1370 x D300 x H450

PLHIGH1370

W1370 x D300 x H800



Planta 1500

Large enough to stand alone or use with furniture settings. 4x 200mm pots.

PLLOW1500

W1500 x D300 x H450

PLHIGH1500

W1500 x D300 x H800



*Plants not provided. Live plants require self-watering system - not provided.

Citi Desks and Screens

Creating an architecturally inspired workspace is now easier with Empire!

The Citi system offers style, uncompromising strength and practicality. The range includes everything you need for a complete office desk and storage system, including add-on elements like divider screens and cable management. Solid steel frame construction and support beams prevent bowing and ensure maximum stability. All Citi items include a 10 Year warranty.

10 YEAR WARRANTY

1. Determine the number of users and desk layout

Desks are available in a variety of shapes and sizes and can either be utilised as single desks or combined into a myriad of settings to suit your space.

WORKTOPS - STRAIGHT

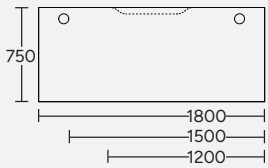

Straight worktops offer choice of 2x cable caps or scallop cable entry

WORKTOPS - L-SHAPE

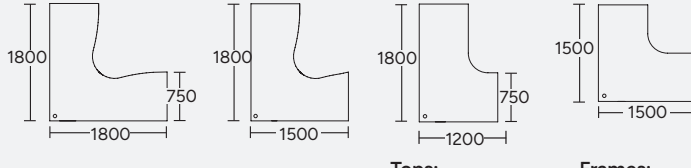

STANDARD COLOURS AND FINISHES:



2. Choose the leg system

Citi is available in standard "50/50" straight legs or contemporary "Loop" and "A-leg" frames. Full fabric panel systems can also be utilised instead of legs - these are called 'Divided' systems.

50/50

LOOP LEG

A-LEG



3. Determine divider screen requirements

The Citi system offers standard Citi divider screens that can be mounted on top of desks or noise-reducing acoustic solutions in the "Acoustico" screens. Alternatively, full height Citi panel screens run from the floor to above the desk, while 'Divided' panel screens go one step further and utilise screens as legs, therefore negating the need for actual 'legs' on the desks.

DESKTOP SCREEN

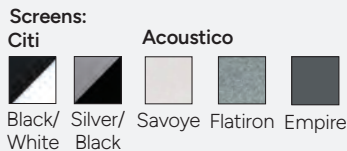
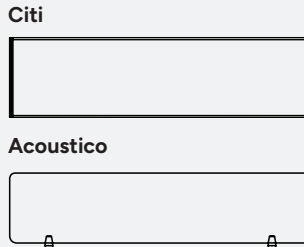

FULL SCREEN HEIGHT

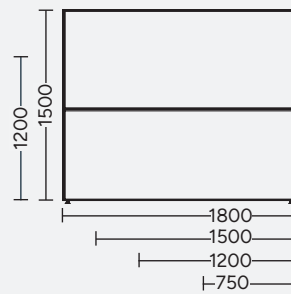

CITI STRAIGHT DESK



4. Determine cable management requirements

Soft wiring, modular wiring or 'plug & play' wiring enables the easy use and re-use of electrical wiring components when installing or re-configuring commercial office workstations without the waste associated with hard-wiring.

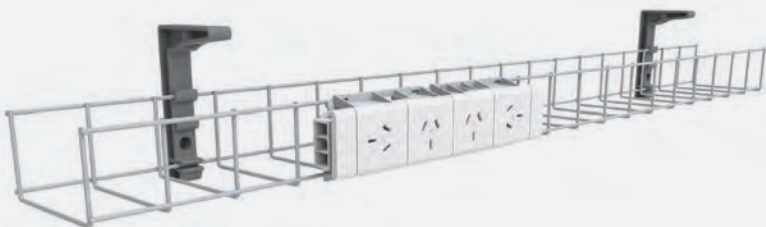

SINGLE SIDED SETTING	
CODE	TOP SIZE
CT#MSSX1275C/S	1200W X 750D
CT#MSSX1575C/S	1500W X 750D
CT#MSSX1875C/S	1800W X 750D

= LEG STYLE (5 = 50/50, A = A-LEG, L = LOOP LEG, 5P = PANEL SYSTEM) X = NO OF USERS

CHOICE OF CITI 480H SCREENS OR NOISE REDUCING ACOUSTICO 420H SCREENS

COMPLETE EXECUTIVE SETTING



Includes:
1800 x 900 50/50 or A-Leg Desk
900 x 600 Return
Breeze Perforated Metal Modesty Panel
Loop Leg (as pictured)
CTLSDKEX1818 + BZCDKMP1800

Citi Desks and Screens



Leg and Modesty finishes: Black White

Top finishes: White Oak Select Beech Red Cherry

*Use "CT5" for 50/50 leg, use "CTA" for A-Leg, use "CTL" for Loop leg



Citi desks are tested to AS/NZS 4442

zero

HOW HEALTHY IS YOUR OFFICE?

EXCLUSIVE TO EMPIRE
Our CITI range uses board containing near to zero formaldehyde...
Does yours?



SEE THE FULL RANGE IN OUR WORKSTATION SYSTEMS CATALOGUE
AT empirefurniture.com.au

SINGLE USER SETTINGS

TOP SIZE (mm)	FREESTANDING DESK & TABLES CODE
1200W X 600D	CTxSDK1260/C
1200W X 750D	CTxSDK1275/C/S
1500W X 750D	CTxSDK1575/C/S
1800W X 750D	CTxSDK1875/C/S
1800W X 900D	CTxSDK1890/C

*Use "CT5" for 50/50 leg, use "CTA" for A-Leg +CT use "CTL" for Loop leg.



CITI WORKSTATION

DIMENSIONS (mm)	CODE
1500W X 1500W X 750D	CTxSWS1515
1800W X 1200W X 750D	CTxSWS1812
1800W X 1500W X 750D	CTxSWS1815
1800W X 1800W X 750D	CTxSWS1818



CITI BACK-TO-BACK (4 PERSON)



CODE	TOP SIZE
CT#MBBX1275C/S	1200W X 750D
CT#MBBX1575C/S	1500W X 750D
CT#MBBX1875C/S	1800W X 750D

= LEG STYLE (5 = 50/50, A = A-LEG, L = LOOP LEG, SP = PANEL SYSTEM) X = NO OF USERS

CITI STANDARD SCREEN FABRICS

White frame/Black fabric
Black frame/Silver fabric

White Oak
ADDITIONAL COLOURS AVAILABLE



MULTI USER SETTINGS - STRAIGHT TOP OPTIONS

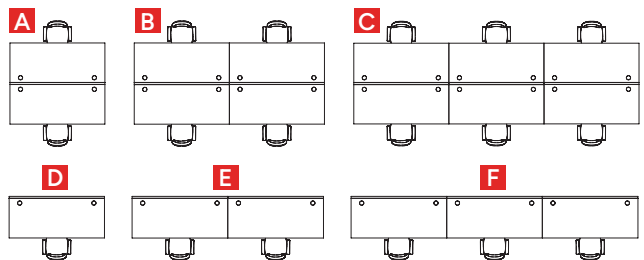

DESK-TOP SCREEN

- 480mm above desk height
- 32mm slimline finish
- Mounted with sturdy steel brackets
- Finish - White or Black powder coated aluminium frame
- Commercial fabric: 2 standard colours (other colours available \$POA)
- "Pinnable" surface

WORK TOP (FINISHED HEIGHT)

- 720 mm + 10 mm ADJUSTABLE FEET
- 25mm E0 Melamine (Environmentally-friendly)
- Choice of 2x Cable entries or a scallop top
- Melamine colour - White or Oak (other colours available \$POA)
- 2mm impact resistant solid PVC edging
- 750mm deep in 3 lengths

Admin Seating

PEDRO RANGE

PEDR23N



OPTIONAL T-ARM (FIXED HEIGHT) ARMKIT20



- Fully ergonomic (tilting seat & back)
- Moulded foam seat
- Black, Red, Blue, Lime & Orange



CONNECTION RANGE



Medium Back CONX23

High Back CONX21

Extra High Back CONX27

Tilting back Gas lift

Tilting back & seat Gas lift

Independent seat/back tilt Large seat

3 lever mechanism



ADJUSTABLE ARM ARMKIT50
FIXED LOOP ARM KIT ARMKIT12

- High back available in Black & Navy fabrics



ERGOFORM



Mesh Back ERGF22M

- Full ergo 3 lever mechanism
- Tilt tension control
- Adjustable height back



Fabric Back ERGF22

OPTIONAL POLISHED BASE ERGFx22P

- Adjustable arms
- Black fabric or Black mesh



ABIGAIL

ABIG14



- Ideal meeting chair
- Single position tilt lock
- Black mesh back with black fabric seat



MAYFIELD

MAYF23



- Gas lift • Tilting back
- Height adj back • Black fabric



FLOW

FLOW23



- Adj ratchet back/lumbar
- Independent tilting seat/back
- Black mesh back

OPTIONAL ADJUSTABLE ARMS ARMKIT29



JEMMA

JJEM21



SUPER-STRONG MECHANISM

- Fully ergonomic • Independent tilting seat and back
- Steel base • Black fabric or Black Leather-Look (PU)

OPTIONAL ARMKIT18



THE MET HIGH BACK

METT12



- Fully ergonomic 3 lever mechanism
- Adjustable arms
- Polished aluminium base
- Ratchet back



Huge Range of Tested

Office Chairs

CHARTER RANGE

- Leather-look (PU) upholstery



Medium Back
CHART14



- Tan leather-look (PU) upholstery



High Back
CHART12



Mesh Back
CHART14M

- Removable arm padding

- Chrome features on Frame/Arms/Gas/Base
- Leather-look (PU) upholstery
- Single position tilt lock mechanism
- High back available in black only

- Black mesh finish
- Chrome base and arms
- Single position tilt lock

EXECUFORM

EEXF22



- High density foam
- Adjustable arm rests
- Extra large moulded seat and back
- Independent back and seat tilt
- Available in Black fabric



10 YEAR WARRANTY

SOUTHPORT LOUNGE



Single
760mm Wide
SOUT01

- 740mm deep
- Black leather-look (PU)
- Also available in 3 seater 1820W SOUT03



Double
1280mm Wide
SOUT02



EASY CHAIR

EASY01



- W590 x D720mm
- Seat height: 410mm
- Black frame and fabric
- More colours available - see pg 90

SALISBURY FOYER CHAIR

SALB



A



Extra Large Salisbury
Also available
SALBXL



B

- Detailed stitch
- High density foam seat
- Steel or timber legs with a re-inforced frame
- Commercial grade upholstery – 50,000 rub test approved

3 YEAR WARRANTY

Standard model includes fabric and 4 leg metal base (Black)

FINISH

4 FABRICS
(Warwick Gravity)
Denim, Navy, Slate, Steel

4 LEATHER GRAIN LOOK FABRICS
(Warwick Eastwood)
Bisan, Donkey, Slate, Tan

3 LEATHER LOOK FABRICS
(Warwick Pelle)
Navy, Sage, Tan

VINYL (V) Black

4 LEG METAL (4LM) – Black

4 LEG METAL (4LM) Lt. Oak, Dark Walnut, Lt. Walnut, Birch

4 LEG TIMBER (4LT) Lt. Oak, Lt. Walnut

STRATA STACKER

SSRA61



- Also available with arms or sled base (\$POA)
- 100's of fabrics (\$POA)
- 2 standard fabrics, Blue or Black



3 YEAR WARRANTY

ZOOM

ZOOM61



WITH ARMS
ZOOM62

SLED BASE
ZOOM71

- Strong, chromed-steel frame
- Mesh back with Black fabric seat



3 YEAR WARRANTY

& Certified Products

Built Strong Tambour Door Cupboards

**NEW AND IMPROVED
GERMAN-ENGINEERED
DOOR SYSTEM**



- Fully assembled
- 900W or 1200W
- Lockable
- Adjustable shelves included
- Available in Black or White
- Attractive roller shutter doors, retract inside the cabinet
- Extra Shelf 900W or 1200W TDBSSH09/12

	Width	Holds Plants	Code
Planter Box Only (No Drip Trays or Plants)	900W	3	PLBS09
	1200W	4	PLBS12
Planter Box with Artificial Plants (No Drip Trays)	900W	3	PLBS09AP
	1200W	4	PLBS12AP
Planter Box for Real Plants* (with Drip Trays)	900W	3	PLBS09DT
	1200W	4	PLBS12DT

10 YEAR WARRANTY **Built STRONG**



*Real plants are not supplied by Empire



Double hook locking system



Levelling feet – adjustable from inside



PLANTER BOX

- 200mm high
- Available in 900W (holds 3 x 200mm dia pots) or 1200W (holds 4 x 200mm dia pots)
- Black or White

CITI MONITOR SINGLE ARM

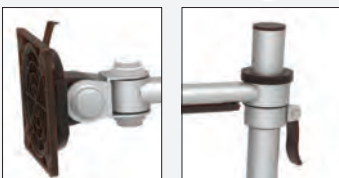

- 442mm arm reach
- Height adjustment 400mm height range
- 80° up/down tilt
- 90° left/right pan

CITI MONITOR DOUBLE ARM



- Quick release for easy screen removal
- 75mm or 100mm VESA compatible
- Weight Capacity 15kg per arm
- Colours: Silver, White or Black

CITI MONITOR SINGLE + LAPTOP



Steel Storage

FILING CABINET

LOCKABLE



- 4 Drawer
1300mm High
FCBS4D
- 3 Drawer
1010mm High
FCBS3D
- 2 Drawer
710mm High
FCBS2D

- W460 x D620mm
- Fully assembled
- Full extension ball bearing runners
- 4 durable powder coat colours: Graphite Ripple, White, Grey & Black Ripple



Built STRONG

10 YEAR WARRANTY

METAL STATIONERY CUPBOARDS

4 Shelves
2100mm High
SCBS21

3 Shelves
1827mm High
SCBS18

2 Shelves
1010mm High
SCBS10



EXTRA SHELF (INCLUDING CLIPS)
SCBSSH

- W905 x D460mm
- Adjustable shelves
- Three point locking mechanism
- Priced in White, Graphite Ripple & Silver Grey
- 15 colours available



Built STRONG

10 YEAR WARRANTY

ALL-STEEL MOBILE PEDESTAL

MPBS2DF

LOCKABLE



Standard Size

Mini Size

- H590 x W390 x D500mm
- Fully assembled
- 2 drawers plus file
- Heavy duty ball bearing runners on file drawer
- White, Graphite Ripple or Black Satin

Built STRONG

10 YEAR WARRANTY

MINI MOBILE PEDESTAL

MPBS1DF

LOW & SLIM SPACE SAVING DESIGN

NEW



SUITABLE FOR HEIGHT ADJUSTABLE DESKS

- 525H x 300W x 500D
- Fully assembled
- 1 drawer plus file
- Heavy duty ball bearing runners on file drawer
- White or Black Satin

Built STRONG

10 YEAR WARRANTY

INDUSTRIAL STEEL SHELVING

SSBS21.SG



EXTRA SHELF
SCBSSH

- 4 adjustable shelves
- H2100 x W905 x D460mm
- Silver Grey



Built STRONG

10 YEAR WARRANTY

LOCKERS (SILVER GREY)

305 Wide

380 Wide



Style	Size	Code
Single Door	305W x 1827H x 460D	LKBS301/K
2 Door	305W x 1827H x 460D	LKBS302/K
4 Door	305W x 1827H x 460D	LKBS304/K
Single Door	380W x 1827H x 460D	LKBS381/K
2 Door	380W x 1827H x 460D	LKBS382/K
4 Door	380W x 1827H x 460D	LKBS384/K

- Also available in banks of 2 or 3

QUICK DELIVERY

Built STRONG

10 YEAR WARRANTY

INDUSTRIAL QUALITY LONG SPAN SHELVING



350kg WEIGHT RATING

Built STRONG

10 YEAR WARRANTY

- High quality all steel construction
- Massive 350 kg per shelf capacity
- Supplied with 2 adjustable shelves and 2 fixed shelves as standard

2100H X 600D	CODE
1000W Initial	LSBS09I
950W Extension	LSBS09E
1900W Initial	LSBS18I
1850W Extension	LSBS18E

EXTRA ADJUSTABLE SHELF (2 PACK)	CODE
900W	LSBS09A
1800W	LSBS18A

Built Strong to Last!

Swatches

VE EO Melamine



VE Bondi



VE Daintree

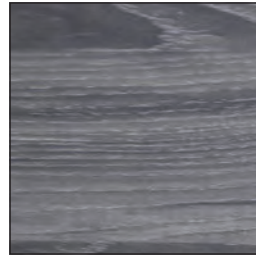

VE Dark Oak



VE Diamond



VE Grey



VE Ironstone



VE Light Oak



VE Natural Oak



VE Pindan



VE Storm

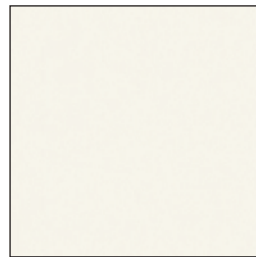

VE White

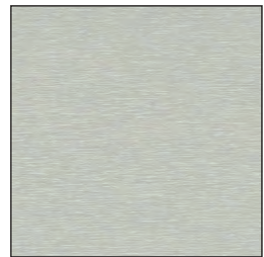

VE Zincworks



VE Writable

VE Fabrics



VE Amazon



VE Fern



VE Moss



VE Wattle



VE Ochre



VE Persian



VE Fox



VE Slate



VE Peat



VE Navy

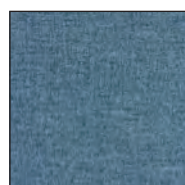

VE Abyss











VE Oasis

Example Colour Palettes

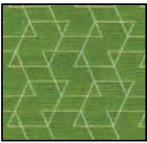
Coastal

Fabric & Vinyl									Acoustic
	Warwick Beachcomber Marine	Instyle Link Incidental	Warwick Keylargo Atlantic	Warwick Keylargo Sky	Warwick Charisma Ocean	Innova Pacifica Marina	Worley Celestial Waterfall	Woven Image Echopanel 633	
Worktops									
	Laminex Coastal Sunrise	Laminex Polar White	Laminex Rural Oak	Laminex Portsea					

Rainforest

Fabric & Vinyl									Acoustic
	Warwick Beachcomber Fern	Warwick Beachcomber Forest	Instyle Link Direct	Warwick Keylargo Wasabi	Instyle Trapeze Elite	Innova Pacifica Spring Bud	Warwick Charisma Sprout	Woven Image Echopanel 381	
Worktops									
	Laminex Planked Urban Oak	Laminex Danish Walnut	Laminex Young Beech	Laminex Bayleaf					

Banksia

Fabric & Vinyl									Acoustic
	Warwick Beachcomber Terracotta	Warwick Keylargo Paprika	Worley Celestial Chilli Pepper	Warwick Beachcomber Manuka	Instyle Trapeze Gala	Innova Pacifica Seal Rock	Warwick Charisma Poppy	Woven Image Echopanel 295	
Worktops									
	Laminex Battalion	Laminex Golden Wattle	Laminex Natural Walnut	Laminex Pillarbox Red					

LAMINEX Commercial board offer



Polar White White Parchment Moleskin Ghostgum Aries Oyster Grey Fox Tornado Lava Grey

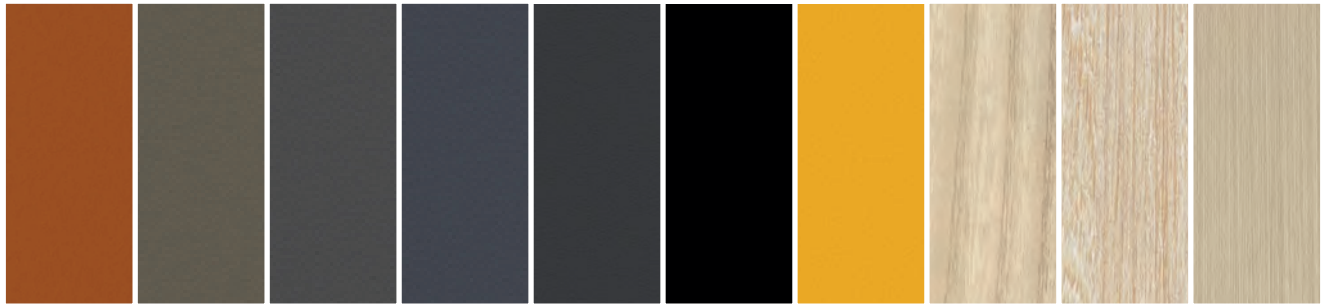

Morrocان Clay Fossil Battalion Charcoal Terril Black Coastal Sunrise Milkwood Seasoned Oak Oyster Linea



Dansk Maple Raw Birchply Silver Ash Young Beech Rock Maple Curly Birch Elegant Oak Select Beech Sublime Teak Classic Oak



Rural Oak Natural Walnut Lustrous Elm Danish Walnut Planked Urban Oak Calm Oak Zincworks Fox Teakwood New Graphite Greystone



Burnished Wood Black Birchply Ottway Spinifex Portsea Golden Wattle Olivine Pillarbox

Laminex offer is for Flint and Natural finish only (Chalk and Nuance \$POA.). For full technical details refer to the Technical Support Information available at laminex.com.au.

POLYTEC Commercial board offer



Polytec swatches and samples represent a small area of the overall colour structure. To view the large colour sample, visit www.polytec.com.au. Dark coloured surfaces will show fingerprints and require more care and maintenance than lighter coloured surfaces. Polytec offer is for Matt finish only (Wood Matt and Ravine \$POA).



Scan To View
Recent Fitouts

University of Southern Queensland

it's easier with
empire
office furniture

SHOWROOMS

SYDNEY

sydney@empirefurniture.com.au
Unit 1/36 Parramatta Road
Lidcombe NSW 2141
Ph: (02) 9000 1564

WOOLLOONGABBA

gabba@empirefurniture.com.au
61 Ipswich Road
Woolloongabba QLD 4102
Ph: (07) 3132 0605

ROCKLEA

rocklea@empirefurniture.com.au
Gate 1, 51-63 Heaton Street
Rocklea QLD 4106
Ph: (07) 3179 6122

VIRGINIA (Relocating January 2025)

virginia@empirefurniture.com.au
1928 Sandgate Road
Virginia QLD 4014
Ph: (07) 3477 9692

SOUTHPORT

southport@empirefurniture.com.au
180 Scarborough Street
Southport QLD 4215
Ph: (07) 5625 7560

SUNSHINE COAST

sunshine@empirefurniture.com.au
Shop E 224 Nicklin Way
Warana QLD 4575
Ph: (07) 5300 2663

ROCKHAMPTON

rockhampton@empirefurniture.com.au
211 East Street
Rockhampton QLD, 4700
Ph: (07) 4800 3003

MACKAY

mackay@empirefurniture.com.au
2B Victoria Street
Mackay QLD 4740
Ph: (07) 4800 4085

TOWNSVILLE

townsville@empirefurniture.com.au
233 Ingham Road
Garbutt QLD 4814
Ph: (07) 4800 4373

 **1800 571 988**
empirefurniture.com.au